

SERVICE INFORMATION

BOOTH EQUIPMENT

Each 10' x 10' booth will be set with 8' high green backwall drape 3' high green side dividers, (1) 6' x 30" green draped table, (2) side chairs by Herman Miller®, and (1) corrugated wastebasket. Booths 300 sq. ft. or less will receive a one-line identification sign. Booths larger than 300 sq. ft. may receive a one-line identification sign upon request.

EXHIBIT HALL CARPET

The exhibit area is carpeted.

DISCOUNT PRICE DEADLINE DATE

Order early on [FreemanOnline](#) to take advantage of advance order discount rates, place your order by THURSDAY, MARCH 12, 2020.

SHOW SCHEDULE

EXHIBITOR MOVE-IN

For more information and helpful hints on pre-show procedures and move-in, please go to [Pre-Show FAQ](#)

Thursday April 2 12:00 p.m. - 7:00 p.m.

NOTE: Overtime rates will apply after 4:30 p.m. on Thursday, April 2, 2020.

All exhibits must be fully installed by 7:00 p.m., Thursday, April 2, 2020.

EXHIBIT HOURS

Friday April 3 11:00 a.m. - 5:00 p.m.

Saturday April 4 10:00 a.m. - 4:00 p.m.

EXHIBITOR MOVE-OUT

For more information and helpful hints on post-show procedures and move-out, please go to [Post-Show FAQ](#)

Saturday April 4 4:00 p.m. - 8:00 p.m.

NOTE: Overtime rates will apply all day during the move out Saturday, April 4, 2020.

SERVICE CENTER HOURS

We will have staff available at show site at the Exhibitor Services Center as follows:

Thursday April 2 12:00 p.m. - 7:00 p.m.

Friday April 3 11:00 a.m. - 5:00 p.m.

Saturday April 4 10:00 a.m. - 8:00 p.m.

DISMANTLE AND MOVE-OUT INFORMATION

- Freeman will begin returning empty crates starting at **4:00 p.m., Saturday, April 4, 2020.**
- All exhibitor materials must be removed from the exhibit facility by **8:00 p.m., Saturday, April 4, 2020.**
- To ensure all exhibitor materials are removed from the exhibit facility by the Exhibitor Move-out deadline, please have all carriers check-in by **6:00 p.m., Saturday, April 4, 2020.**

POST SHOW PAPERWORK AND LABELS

Our Exhibitor Services Department will gladly prepare your outbound Material Handling Agreement and Labels in advance. Complete the Outbound Shipping form and your paperwork will be available at show site. Be sure your carrier knows the company name and booth number when making arrangements for shipping your exhibit at the close of the show.

EXCESSIVE TRASH AND BOOTH ABANDONMENT

Any excessive trash which consists of display materials, carpet, padding, crates and/or pallets will be disposed of and charged both a handling fee and disposal fee during exhibitor move-in. Excessive booth materials and/or literature left in the booth at the end of the published exhibitor move-out that is not labeled for an outbound shipment will be considered abandoned and deemed as trash. The exhibitor will be charged for the removal and disposal of these items. Charges may include Installation & Dismantle Labor, Forklift/Rigging Labor, and/or Dumpster Fee. Please call our Exhibitor Services Department at (773) 473-7080 for a quote.

SERVICE CONTRACTOR CONTACTS / INFORMATION:

FREEMAN

8201 West 47th Street
 McCook, IL 60525
 (773) 473-7080 • Fax (469) 621-5603
 Email: FreemanChicagoES@freeman.com

FREEMAN EXHIBIT TRANSPORTATION

(800) 995-3579 Toll Free US & Canada
 Fax (469) 621-5810
 (817) 607-5183 / (512) 982-4187 Local & International
 Email: Exhibit.Transportation@freeman.com

FREEMAN ONLINE®

Take advantage of discount pricing by ordering online at [FreemanOnline](#) by **THURSDAY, MARCH 12, 2020**. Using the enhanced FreemanOnline, you will enjoy easy access to added features and functions as well as the high caliber of Freeman services you've come to expect — **before, during and after** your show.

To place online orders, you will be required to enter your unique Username and Password. If this is your first time to use FreemanOnline, click on the "Create an Account" link. To access Freeman Online without using the email link, visit [FreemanOnline](#).

If you need assistance with FreemanOnline, please call our Customer Support Center at (888) 508-5054 Toll Free US and Canada or +1 (512) 982-4186 or +1 (817) 607-5000 Local and International.

SHIPPING INFORMATION

Warehouse shipping address:

NECANN - ILLINOIS CANNABIS CONVENTION
 Exhibiting Company Name
 Booth # _____
 c/o FREEMAN
 2500 West 35th Street
 Chicago, IL 60632

NOTE: Any shipment that has a single piece that weighs over 5,000 lbs. MUST have that shipment delivered direct to Show Site and NOT to Freeman's Advance Receiving Warehouse.

Freeman will accept crated, boxed or skidded materials beginning **THURSDAY, MARCH 5, 2020** at the above address. Materials arriving after **THURSDAY, MARCH 26, 2020** will be received at the warehouse with an additional after deadline charge. Please note that the Freeman Warehouse does not accept uncrated freight (loose, pad-wrapped material and/or unskidded machinery), COD shipments, hazardous materials, freight requiring refrigerated or frozen storage or a single piece of freight beyond the dimensions of 108" H x 93" W. Certified weight tickets must accompany all shipments.

Warehouse receiving hours are 8:00 a.m. to 3:30 p.m. Monday through Friday.

Do NOT ship advance freight to the Hilton Chicago. The hotel has NO storage facilities and *the freight will be returned to the sender*. Any charges incurred for early freight accepted by the facility are the responsibility of the Exhibitor. Certified weight tickets must accompany all shipments. Freeman will accept **DIRECT** freight shipments at the Hilton Chicago Hotel, 725 South Wabash Avenue, Chicago, IL 60605 on **THURSDAY, APRIL 2, 2020 at 12:00 p.m.** for all exhibit halls.

Please note: Any materials received by Freeman are subject to Material Handling Charges and are the responsibility of the Exhibitor. This also applies to items not ordered through the Official Show Vendors. Refer to the material handling form for charges for the service.

Please be aware that disposal of exhibit properties is not included as part of your material handling charges. Please contact Freeman for your quoted rates and rules applicable to disposal of your exhibit properties.

LABOR INFORMATION

Union Labor may be required for your exhibit installation and dismantle. Please carefully read the UNION RULES AND REGULATIONS to determine your needs. Exhibitors supervising Freeman labor will need to pick up and release their labor at the Service Desk. Refer to the order form under Display Labor for Straight time and Overtime hours.

ASSISTANCE

We want you to have a successful show. If we can be of assistance, please call our Exhibitor Services Department at (773) 473-7080.

WE APPRECIATE YOUR BUSINESS!

FREEMAN GENERAL INFORMATION

TRANSLATION SERVICE

Freeman is pleased to offer a new service for our international exhibitors that provides quick interpretation and translation in 150 languages. This service will not only interpret for us on a three-way conversation, but also translate emails from customers. To access this service you may contact Freeman (add the branch name) Exhibitor Services at (their phone number) or Freeman's Customer Support Center at (888)508-5054 US & Canada or +1(512) 982-4186 Local & International.

HELPFUL HINTS

SAVE MONEY

Order early on [FreemanOnline](#) to take advantage of advance order discount rates, place your order by **THURSDAY, MARCH 12, 2020.**

AVOID DELAY

Ship early to avoid delays. Shipments arriving late at show site will cost you money, time and business!

SAFETY TIPS

Use a ladder, not a chair. Standing on chairs, tables and other rental furniture is unsafe and can cause injury to you or to others. These objects are not designed to support your standing weight.

Be aware of your surroundings. You are in an active work area with changing conditions during move-in and move-out. Pay attention. Look for obstacles, and machinery and equipment that are in use.

Keep your eyes open for scooters and forklifts. The drivers of these vehicles may not be able to see you.

Stay clear of dock areas, trucks and trailers. These areas can be particularly dangerous.

Prevent electrical shocks, falling items and damage to materials. Do not attach items or equipment to the drapes or metal framework provided for you booth. This can cause serious injury or damage to materials.

We discourage children from being in the exhibit hall during installation and dismantle. If children are present during installation and dismantle, they must be supervised by an adult at all times.

Freeman does not ship or handle Hazardous Materials. If any materials you are shipping to the event fall into this category, please contact Freeman to be sure that the material will be allowed at the facility and by the association. In addition, if authorized by the facility and the association, you will need to make separate arrangements for the transport and handling of the approved materials, since Freeman will not transport or handle them.

The operation or use of all motorized lifts and motorized material handling equipment for installation/dismantle of exhibits is NOT permitted by exhibitors or by their exhibitor appointed contractors (EAC's). Thank you for your cooperation

EXHIBITOR ASSISTANCE

For more information and helpful hints on pre-show procedures and move-in, please go to [Pre-Show FAQ](#)

For more information and helpful hints on post-show procedures and move-out, please go to [Post-Show FAQ](#)

Call Freeman's Exhibitor Services department at (773-473-7080) with any questions or needs you may have.

Interested in going green and saving money?

Follow these tips to make sure your sustainable booth strategies are cost-neutral or even cost-saving! Leave an impact on the show floor, not the environment.



1 BEFORE THE SHOW

booth structure

Option 1 Multiple Use

Use **Forest Sustainable Certified (FSC)** wood to build your booth and crates.

Get creative! Design your booth with a **small shipping footprint** to minimize carbon emissions. Freeman's eye-catching stretch-fabric booth designs pack up small (and light!) for shipping.

Option 2 One-time Use

Rent locally from nearby Freeman offices to reduce both shipping costs and carbon emissions.

2 carpet

Option 1 Rent

Rent rather than buy carpet to save on shipping, cleaning, and storage. Freeman Classic carpet can be reused at least four times.

Option 2 Color

Use darker-colored carpet, which is easier to reuse and recycle. Freeman Classic dark-colored carpets are made of 20-50 percent recycled content.



3 shipping

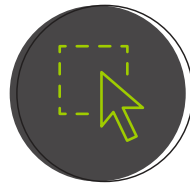

Online + before deadline = better bottom line. Take advantage of early-bird pricing and consolidate shipping when ordering supplies.

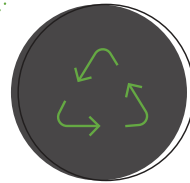

Choose reusable shipping padding. Avoid packing peanuts and foam plastic materials that never decompose.



Ship early. Use the 30-day policy to ship materials to the Freeman advance warehouse.

4 graphics

Option 1 Multiple Use

Print on a durable substrate **without dates, event names, or locations.**

Option 2 One-time Use

Print on 100 percent recyclable materials like Freeman Honeycomb and Smartbuild Eco, which are just as cost-effective as PVC.

5 printing



Reduce printing and **go digital** with your booth literature.



Print locally. Supporting local businesses while reducing shipping? It's a win-win.



Print on at least **50 percent post-consumer recycled paper.**

6

ON SITE

save energy



Use Energy Star-rated equipment for audio-visual equipment and monitors.



Power down. Turn off equipment at the end of each day.



Light up your booth with CFLs, LEDs, or other energy-efficient lighting.

8

shipping out

Pack in, pack out.

Leave no traces on show site.

Join a caravan.

If you're shipping directly to another show, ask **Freeman Transportation about joining a caravan** to your next show.

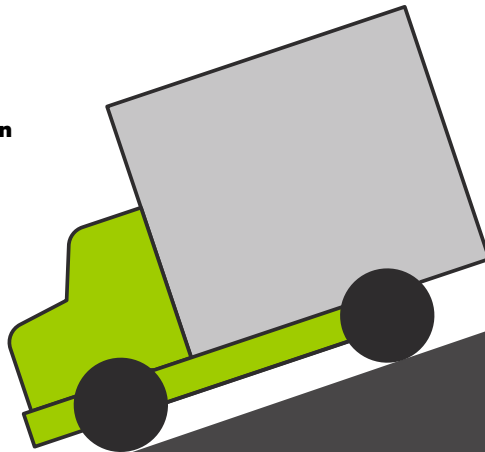

9

leftover materials

Remember to label.

Clearly **label recyclable leftover material** for disposal.

Donate the rest.

Ask the Freeman Exhibitors Services desk about local donation programs.

7

MOVE OUT

train your team

Educate your installation and dismantling teams about **recycling and donation processes.**



**TYPICALLY*
DONATE-ABLE**

Furniture: Purchased items
Home furnishing: Décor staging materials

Unused raw materials: Plywood, subflooring, non-laminate wood

Flooring: 100 square feet of flooring. Excludes carpet.

Left over giveaways: Pens, pads of paper, sunglasses, USBs, etc., left over in your promotional giveaway

**TYPICALLY*
RECYCLABLE**

Cardboard: Used for signs or shipping boxes

Glass: Green, brown, clear

Plastics: Shrink-wrap or plastic banding used to secure shipments; water/soda bottles; plexiglass (acrylics) clear, smoked, or tinted; Visqueen used to protect flooring

Metal: Aluminum cans/ steel banding

Paper: Fliers, brochures, programs, tickets, office paper, newspaper, magazines, paperboard

Wood: Non-laminate wood

FREEMAN

8201 West 47th Street
McCook, Illinois 60525
(773) 473-7080 • Fax (469) 621-5603
Email: FreemanChicagoES@freeman.com

DISCOUNT PRICE
DEADLINE DATE
MARCH 12, 2020

INCLUDE THIS FORM WITH YOUR ORDER
PLEASE USE BLACK INK

NAME OF SHOW:	NECANN - ILLINOIS CANNABIS CONVENTION / APRIL 3 - 4, 2020		
COMPANY NAME:		BOOTH#:	
ADDRESS:		BOOTH SIZE	X
CITY/STATE/ZIP:			
CONTACT NAME:		PHONE #:	
CONTACT EMAIL:			

Payment Information

Freeman only accepts payment information electronically. Place your order on FreemanOnline or follow the steps below to provide your payment information electronically and submit your order forms.

Freeman will no longer accept cash payments for any Freeman Services.

1. Submit your payment information

Proceed to our electronic Freeman Pay site to securely submit your payment information

<https://www.freemanpay.com/500503>

2. Submit your order

Upload your order forms through the same link used to submit your payment information

- Both your order and your payment must be received by the discount deadline date to guarantee discount pricing.
- Orders received without payment or after the discount price deadline date will be charged at the standard price.
- Copies of invoices may be picked up from the Freeman Service Center prior to show closing.

FREEMAN method of payment

PAYMENT & LABOR

YOU ARE ENTERING A CONTRACT WHICH LIMITS YOUR POSSIBLE RECOVERY IN CASE OF LOSS OR DAMAGE.

The terms and conditions set forth below become a part of the Contract between FREEMAN and you, the EXHIBITOR. Acceptance of said terms and conditions will be construed when any of the following conditions are met:

- THE METHOD OF PAYMENT FORM IS SIGNED; OR
- AN ORDER FOR LABOR, SERVICES AND/OR RENTAL EQUIPMENT IS PLACED BY EXHIBITOR WITH FREEMAN; OR
- WORK IS PERFORMED ON BEHALF OF EXHIBITOR BY LABOR SECURED THROUGH FREEMAN.

DEFINITIONS

For purposes of this Contract, "FREEMAN" or "The Freeman Companies" means Freeman Expositions, LLC., Freeman Expositions, Ltd., Freeman Audio Visual, Inc., Exhibit Surveys, LLC., Freeman Exhibit, Freeman Transportation, FreemanXP, LLC., Stage Rigging, LLC., The Freeman Company, Freeman Electrical, LLC., Freeman Digital Ventures, LLC., and their respective employees, directors, officers, agents, assigns, affiliated companies, and related entities including, but not limited, to any subcontractors FREEMAN may appoint. The term "EXHIBITOR" means the Exhibitor, its employees, agents, representatives, and any Exhibitor Appointed Contractors ("EAC").

PAYMENT TERMS

Full payment, including any applicable tax, is due in advance or at show site. All payments must be in U.S. secure funds and all checks must be drawn on a U.S. bank. Orders received without advance payment or after the deadline date will incur additional charges as indicated on each order form. Payment for Audio Visual services and equipment is due in advance of move-in, unless otherwise agreed in writing with Freeman. All materials and equipment are on a rental basis for the duration of the show or event and remain the property of FREEMAN except where specifically identified as a sale. All rentals (excluding Audio Visual equipment and computers) include delivery, installation, and removal from EXHIBITOR'S booth. Rental prices on Audio Visual equipment and computers do not include labor, delivery, electrical services or removal of the equipment from the booth. In case of cancellation of any orders or services by EXHIBITOR, a one-hour "per person, per hour" charge will be applied for all labor orders that are not canceled in writing at least 24 hours prior to the scheduled start time. If Prestige Carpet, Custom-Cut Carpet, Modular Rental Exhibits and any other custom-order items or services have already been provided at the time of cancellation, fees will remain at 100% of the original charge. Audio Visual orders cancelled within 7 days from the show opening date will be charged a one-day rental rate on equipment. On-site cancellation of Audio Visual services will result in a one-day rental charge of equipment and any applicable labor. If the Show or Event is canceled because of reasons beyond FREEMAN'S control, EXHIBITOR remains responsible for all charges for services and equipment provided up to and including the date of cancellation. FREEMAN will not issue refunds to EXHIBITOR of any payments made before the date of cancellation. It is EXHIBITOR'S responsibility to advise the FREEMAN Service Center Representative of problems with any orders, and to check the EXHIBITOR'S invoice for accuracy prior to the close of the Show or Event. If EXHIBITOR is exempt from payment of sales tax, FREEMAN requires an exemption certificate for the State in which the services are to be used. Resale certificates are not valid unless EXHIBITOR is rebilling these charges to its customers. For International EXHIBITORS, FREEMAN requires 100% prepayment of advance orders, and any order or services placed at show site must be paid at the show. For all others, should there be any pre-approved unpaid balance after the close of the show; terms will be net, due and payable in DALLAS, TEXAS upon receipt of invoice. Effective 30 days after invoice date, any unpaid balance will bear a FINANCE CHARGE at the lesser of the maximum rate allowed by applicable law, or 1.5% per month, which is an ANNUAL PERCENTAGE RATE of 18%, and future orders will be on a prepaid basis only. If any finance charge hereunder exceeds the maximum rate allowed by applicable law, the finance charge shall automatically be reduced to the maximum rate allowed, and any excess finance charge received by FREEMAN shall be either applied to reduce the principal unpaid balance or refunded to the payer. If past due invoices or invoice balances are placed with a collection agency or attorney for collection or suit, EXHIBITOR agrees to pay all legal and collection costs. THESE PAYMENT TERMS AND CONDITIONS SHALL BE GOVERNED BY AND CONSTRUED IN ACCORDANCE WITH THE LAWS OF THE STATE OF TEXAS. In the event of any dispute between the EXHIBITOR and FREEMAN relative to any loss, damage, or claim, such EXHIBITOR shall not be entitled to and shall not withhold payment, or any partial payment, due to FREEMAN for its services, as an offset against the amount of any alleged loss or damage. Any claims against FREEMAN shall be considered a separate transaction, and shall be resolved on its own merits. FREEMAN reserves the right to charge EXHIBITOR for the difference between the EXHIBITOR'S estimate of charges and the actual charges incurred by EXHIBITOR, or for any charges that FREEMAN may be obligated to pay on behalf of EXHIBITOR, including without limitation, any shipping charges. If EXHIBITOR provides a credit card for payment and the credit card transaction is declined, EXHIBITOR hereby authorizes Freeman to process the outstanding balance in multiple smaller increments that total the amount of the outstanding payment obligation. In the event that a THIRD PARTY (AGENT) orders on behalf of the EXHIBITOR and the named THIRD PARTY does not discharge payment of the invoice prior to the last day of the show, charges will revert back to the EXHIBITOR. All invoices are due and payable upon receipt, by either party.

ELECTRICAL

If FREEMAN provides electrical services, claims will not be considered, or adjustments made unless filed in writing, by EXHIBITOR, prior to the close of the event. FREEMAN is not responsible for any damage or loss caused by the loss of power beyond its control and EXHIBITOR agrees to hold FREEMAN, its officers, directors, employees and agents harmless from such power loss. IN NO EVENT SHALL FREEMAN BE LIABLE FOR ANY INDIRECT OR CONSEQUENTIAL DAMAGES (INCLUDING WITHOUT LIMITATION LOST PROFITS) EVEN IF ADVISED OF THE POSSIBILITY OF SUCH DAMAGES, WHETHER UNDER THEORY OF CONTRACT, TORT (INCLUDING NEGLIGENCE), PRODUCTS LIABILITY OR OTHERWISE. EXHIBITOR shall indemnify and hold harmless FREEMAN, its officers, directors, employees, and agents from and against any and all claims, liabilities, damages, fines, penalties or costs of whatsoever nature (including reasonable attorneys' fees) arising out of or in any way connected with EXHIBITOR'S actions or omissions under this Agreement. Please note that electrical services are NOT automatically included in Audio Visual rentals and must be ordered separately from the designated electrical provider.

LABOR UNDER THE SUPERVISION OF EXHIBITOR RESPONSIBILITIES

EXHIBITOR shall be responsible for the performance of labor provided under this option. It is the responsibility of EXHIBITOR to supervise labor secured through FREEMAN in a reasonable manner as to prevent bodily injury and/or property damage and also to direct them to work in a manner that is in compliance with FREEMAN'S Safe Work Rules and/or Federal, State, County and Local ordinances, rules and/or regulations, including but not limited to Show or Facility Management rules and/or regulations. If any labor secured through Freeman is conducting overhead work, the Exhibitor is responsible for ensuring that everyone in the area of overhead work is wearing a hard hat. If the Exhibitor does not have its own hard hats, Freeman can assist with obtaining them. It is the responsibility of EXHIBITOR to check in with the Service Desk to pick up labor, and to return to the Service Desk to release labor when the work is completed.

INDEMNIFICATION

EXHIBITOR agrees to indemnify, hold harmless, and defend FREEMAN from and against any and all demands, claims, causes of action, fines, penalties, damages, liabilities, judgments, and expenses (including but not limited to reasonable attorneys' fees and investigation costs) for bodily injury, including any injury to FREEMAN employees, and/or property damage arising out of work performed by labor provided by FREEMAN but supervised by EXHIBITOR. Further, the EXHIBITOR'S indemnification of FREEMAN includes any and all violations of Federal, State, County or Local ordinances, "Show Regulations and/or Rules" as published and/or set forth by Facility or Show Management, and/or directing labor provided by FREEMAN to work in a manner that violates any of the above rules, regulations, and/or ordinances.

IMPORTANT

PLEASE REFER TO FREEMAN'S "MATERIAL HANDLING TERMS & CONDITIONS" AS IT RELATES TO MATERIAL HANDLING SERVICES AND TO THE "SERVICE REQUEST & SHIPPING INSTRUCTIONS CONTRACT" AS IT RELATES TO TRANSPORTATION SERVICES. CONTRACT TERMS DEPEND ON THE NATURE OF SERVICES SECURED BY EXHIBITOR THROUGH FREEMAN. TERMS & CONDITIONS MAY VARY FOR EACH TYPE OF SERVICE ORDERED THROUGH FREEMAN.

MATERIAL HANDLING

YOU ARE ENTERING A BINDING CONTRACT WHICH LIMITS YOUR POSSIBLE RECOVERY IN CASE OF LOSS OR DAMAGE. Acceptance of said terms and conditions will be construed when any of the following conditions are met: This Material Handling Agreement (MHA) is signed; Exhibitor's materials are delivered to Freeman's warehouse or to an event site for which Freeman is the Official Show Contractor; or an order for labor and/or rental equipment is placed by Exhibitor with Freeman. Please be aware that disposal of exhibit properties is not included as part of your material handling charges. Please contact Freeman for your quoted rates and rules applicable to disposal of your exhibit properties.

1. DEFINITIONS. For purposes of this Contract, Freeman means Freeman Expositions, Inc., and its employees, directors, officers, agents, assigns, affiliated companies, and related entities. In no event shall Freeman be deemed to be the Ultimate Consignee for shipping and custom purposes. The term "Exhibitor" means the Exhibitor, its employees, agents, and representatives.

2. PACKAGING/CRATES AND STORAGE. Freeman shall not be responsible for damage to loose or uncrated materials, pad wrapped or shrink-wrapped materials, glass breakage, concealed damage, carpets in bags or poly, or improperly packed or labeled materials. Freeman shall not be responsible for crates and packaging which are unsuitable for handling, in poor condition, or have prior damage. Crates and packaging should be of a design to adequately protect contents for handling by forklift and similar means. Freeman does not accept any crates or packaging containing hazardous materials. Goods requiring cold storage and those in accessible storage are stored at Exhibitor's own risk. **FREEMAN ASSUMES NO RESPONSIBILITY OR LIABILITY FOR LOSS OR DAMAGE TO GOODS IN COLD STORAGE OR ACCESSIBLE STORAGE.**

3. EMPTY CONTAINERS. Empty container labels will be available at the show site service desk. Affixing labels to the containers is the sole responsibility of Exhibitor or its representative. All previous labels must be removed or obliterated. Freeman assumes no responsibility for: error in the above procedures; removal of containers with old empty labels and without Freeman labels; or improper information on empty labels. **FREEMAN WILL NOT BE LIABLE FOR LOSS OR DAMAGE TO CRATES AND CONTAINERS OR THEIR CONTENTS WHILE SAME ARE IN EMPTY CONTAINER STORAGE.**

4. INBOUND/OUTBOUND SHIPMENTS. There may be a lapse of time between the delivery of shipment(s) to the booth and the arrival of Exhibitor, or a lapse of time between the completion of packing and the actual pickup of materials from the booths for loading onto a carrier and during such times, Exhibitor materials will be left unattended. **FREEMAN IS NOT RESPONSIBLE OR LIABLE FOR ANY LOSS, DAMAGE, THEFT, OR DISAPPEARANCE OF EXHIBITOR'S MATERIALS AFTER THEY HAVE BEEN DELIVERED TO EXHIBITOR'S BOOTH THAT SHOW SITE OR BEFORE THEY HAVE BEEN PICKED UP FOR RELOADING AT THE CONCLUSION OF THE EVENT.** Freeman recommends the securing of security services from Facility or Show Management. All MHA's submitted to Freeman by Exhibitor will be checked at the time of pickup from the booth and corrections will be made where discrepancies exist between the quantities of items on any form submitted to Freeman and the actual count of such items in the booth at the time of pickup. Freeman is not responsible for any wait time or other charges including business center charges arising from delivery or pickup of Exhibitor's materials.

5. DELIVERY TO THE CARRIER FOR RELOADING. Freeman assumes no responsibility for loss, damage, theft, or disappearance of Exhibitor's materials after same have been delivered to Exhibitor's appointed carrier, shipper, or agent for transportation after the conclusion of the show. Freeman loads the materials onto the carrier under directions from the carrier or driver of that carrier. Any loading onto the carrier will be understood to be under the exclusive supervision and control of the carrier or driver of that carrier. **FREEMAN ASSUMES NO RESPONSIBILITY FOR LOSS, DAMAGE, THEFT OR DISAPPEARANCE OF EXHIBITOR'S MATERIALS THAT ARISES OUT OF IMPROPERLY LOADED OR LABELED MATERIALS.**

6. DESIGNATED CARRIERS. Freeman shall have the authority to change the Exhibitor designated carrier if that carrier does not pick up the shipment(s) at the appointed time. Where no disposition is made by Exhibitor, materials may be taken to a warehouse to await Exhibitor's shipping instructions and Exhibitor agrees to be responsible for charges relating to such rerouting and handling. **IN NO EVENT SHALL FREEMAN BE RESPONSIBLE FOR ANY LOSS RESULTING FROM SUCH REROUTING DESIGNATION.**

7. FORCE MAJEURE. Freeman's performance hereunder is subject to, and Freeman shall not be responsible for loss, delay, or damage due to, strike, work stoppages, natural elements, vandalism, Act of God, civil disturbances, power failures, explosions, acts of terrorism or war, or for any other cause beyond Freeman's reasonable control, nor for ordinary wear and tear in the handling of Exhibitor's materials.

8. CLAIM(S) FOR LOSS. Exhibitor agrees that any and all claims for loss or damage must be submitted to Freeman immediately at the show site and in any case not later than **thirty (30) business days** after the date when Exhibitor's materials are delivered to the carrier for transportation from show site or from Freeman's warehouse. All claims reported after thirty (30) days will be rejected. In no event shall a suit or action be brought against Freeman **more than one (1) year** after the date of loss or damage occurred.

a. PAYMENT FOR SERVICES MAY NOT BE WITHHELD. In the event of any dispute between the Exhibitor and Freeman relative to any loss, damage, or claim, Exhibitor shall not be entitled to and shall not withhold payment due Freeman for its services as an offset against the amount of any alleged loss or damage. Any claims against Freeman shall be considered a separate transaction and shall be resolved on their own merits.

b. MAXIMUM RECOVERY. If found liable for any loss, Freeman's sole and exclusive maximum liability for loss or damage to Exhibitors materials and Exhibitor's sole and exclusive remedy is limited to \$50 (USD) per pound per article with a maximum liability of \$100.00 (USD) per item, or \$1,500.00 (USD) per shipment whichever is less. All shipment weights are subject to correction and final charges determined by the actual or re-weighted weight of the shipment.

c. LIMITATION OF LIABILITY. IN NO EVENT SHALL FREEMAN BE LIABLE TO THE EXHIBITOR OR TO ANY OTHER PARTY FOR SPECIAL, COLLATERAL, EXEMPLARY, INDIRECT, INCIDENTAL, OR CONSEQUENTIAL DAMAGES, WHETHER SUCH DAMAGES OCCUR EITHER PRIOR OR SUBSEQUENT TO, OR ARE ALLEGED AS A RESULT OF, TORTIOUS CONDUCT, FAILURE OF THE EQUIPMENT OR SERVICES OF FREEMAN OR BREACH OF ANY OF THE PROVISIONS OF THIS CONTRACT, REGARDLESS OF THE FORM OF ACTION, WHETHER IN CONTRACT OR IN TORT, INCLUDING STRICT LIABILITY AND NEGLIGENCE, EVEN IF FREEMAN HAS BEEN ADVISED OR HAS NOTICE OF THE POSSIBILITY OF SUCH DAMAGES. SUCH EXCLUDED DAMAGES INCLUDE BUT ARE NOT LIMITED TO LOST PROFITS, LOSS OF USE, AND INTERRUPTION OF BUSINESS OR OTHER CONSEQUENTIAL OR INDIRECT ECONOMIC LOSSES.

9. DECLARED VALUE. Declarations of Declared Value are between the Exhibitor and the selected Carrier ONLY, and are in no way an extension of Freeman's maximum liability stated herein. Freeman will use commercially reasonable efforts to transmit the Declared Value instructions to the selected Carrier; however, **FREEMAN WILL NOT BE LIABLE FOR ANY CLAIM ARISING FROM THE TRANSMITTAL OF, OR FAILURE TO TRANSMIT, DECLARED VALUE INSTRUCTIONS TO THE CARRIER NOR FOR FAILURE OF THE CARRIER TO UPHOLD THE DECLARED VALUE OR ANY OTHER TERM OF CARRIAGE.**

10. JURISDICTION / VENUE. THIS CONTRACT SHALL BE CONSTRUED UNDER THE LAWS OF THE STATE OF TEXAS WITHOUT GIVING EFFECT TO ITS CONFLICT OF LAWS RULES. EXCLUSIVE VENUE FOR ALL DISPUTES ARISING OUT OF OR RELATING TO THIS CONTRACT SHALL RESIDE IN A COURT OF COMPETENT JURISDICTION IN DALLAS COUNTY, TEXAS.

11. INDEMNIFICATION. Exhibitor agrees to indemnify and forever hold harmless Freeman from and against any and all demands, claims, causes of action, fines, penalties, damages (including consequential), liabilities, judgments, and expenses (including but not limited to reason-able attorneys' fees and investigation costs) arising out or contributed to by Exhibitor's negligent supervision of any labor secured through Freeman; Exhibitor's negligence, willful misconduct, or deliberate act, or the negligence, willful misconduct, or deliberate act of Exhibitor's employees, agents, representatives, customers, invitees and/or any Exhibitor Appointed Contractors (EAC) at the show or event to which this Contract relates, including but not limited to Exhibitor's violation of Federal, State, County or Local ordinance and/or Exhibitor's violation of Show Regulations and/or Rules as published and set forth by Facility and/or Show Management.

12. LIEN. Exhibitor grants Freeman a security interest in and a lien on all of Exhibitor's materials that is from time to time in the possession of Freeman and all the proceeds thereof, including without limitation insurance proceeds (the "Collateral"), to secure the prompt and full payment and performance of all Exhibitor's indebtedness for monies paid, by Freeman on its behalf, services performed, materials and/or labor from time to time provided by Freeman to or for the benefit of Exhibitor ("Obligations"). Freeman shall have all the rights and remedies of a secured party under the Uniform Commercial Code, as may be amended from time to time ("UCC"), and any notice that Freeman is required to give under the UCC of a time and place of a public sale or the time after which any private sale or other intended disposition of any Collateral is to be made shall be deemed to constitute reasonable notice if such notice is mailed by registered or certified mail at least five (5) days prior to such action. Freeman may hold and not deliver any of the Collateral to Exhibitor for so long as there are any Obligations that remain unpaid or unsatisfied.

13. WAIVER & RELEASE. Exhibitor, as a material part of the consideration to Freeman for material handling services, waives and releases all claims against Freeman with respect to all matters for which Freeman has disclaimed liability pursuant to the provisions of this Contract.

14. DRIVER LIABILITY WAIVER. IN CONSIDERATION OF FREEMAN PERMITTING ENTRANCE TO THE PREMISES, YOU, YOUR EMPLOYER, THE OWNER OF THE TRUCK AND/OR EQUIPMENT THAT YOU ARE OPERATING (TRUCKOWNER) AND YOU AS AGENT OF YOUR EMPLOYER AND THE TRUCKOWNER, HEREBY ASSUME ALL RISK OF INJURY OR HARM TO YOURSELF AND OTHERS AND DAMAGE TO YOUR PROPERTY AND PROPERTY BELONGING TO YOU OR YOUR EMPLOYER OR OTHERS ARISING FROM YOUR ACTIVITIES WHILE BEING PERMITTED TO ENTER THE PREMISES. YOU AGREE TO ENTER AT YOUR OWN RISK. YOU HAVE FULL KNOWLEDGE OF ANY RISK INVOLVED IN THIS ACTIVITY. YOU RECOGNIZE THE HAZARDS AND ARE AWARE OF ALL THE RULES FOR SAFE OPERATION. YOU, YOUR EMPLOYER, THE TRUCKOWNER, AND YOU AGREE TO INDEMNIFY AND HOLD HARMLESS FREEMAN, ITS EMPLOYEES, OFFICERS, DIRECTORS, AGENTS, ASSIGNS, AFFILIATED COMPANIES AND RELATED ENTITIES, AGAINST ANY AND ALL LIABILITY, ACTIONS, CLAIMS, AND DAMAGES OF ANY KIND WHATSOEVER ARISING FROM YOUR ACTIVITIES WHILE BEING PERMITTED TO ENTER THE PREMISE.

AIR CARGO

AIR CARGO SERVICE REQUEST AND SHIPPING INSTRUCTIONS CONTRACT

In tendering this shipment, the Shipper and Consignee agree to these TERMS which no agent or employee of the parties may alter. This Air Service Request and Shipping Instruction Contract is NON-NEGOTIABLE and has been prepared by Shipper, or if by Freeman or another on Shipper's behalf, it shall be deemed, conclusively, to have been prepared by the Shipper. The Shipper agrees that this shipment is subject to the TERMS stated herein All TERMS, including but not limited to, all the limitations of liability, shall apply to our agents and their contracting carriers.

1. DEFINITIONS: In this Contract, "Freeman" means Freeman Decorating Services, Inc., and its respective employees, officers, directors, agents, assigns, affiliated companies, and related entities including any contractors appointed by Freeman. The term "Shipper" means the person or business for whom the property is being transported, and includes their respective employees, officers, directors, agents, assigns, affiliated companies, and contractors appointed by the Shipper, excluding only Freeman. "Property" is all objects of any type received from the Shipper for transport by Freeman as described herein. "Consignee" is the party to whom Shipper has designated the goods are to be delivered.

2. FINAL CONTRACT BETWEEN THE PARTIES: In exchange for Shipper's payments and Freeman's services, which the parties have specified in this two-page Contract (including the Air Cargo Service Request and Shipping Instructions), Freeman and Shipper each agree that this Contract shall govern their respective rights and obligations regarding transportation of Shipper's property. This Contract shall take effect when the property first comes into the physical possession of Freeman, and the responsibility of Freeman under same shall end when the property has been placed in the possession of the Consignee or the Consignee's designated agent. If any part or provision of this Contract is found by a court of competent jurisdiction to be void or unenforceable, the remainder of the Contract shall continue in full force and effect.

3. Freeman's RESPONSIBILITIES UNDER THE CONTRACT ARE LIMITED: Freeman is responsible for the satisfactory performance of only those services which it directly provides under this Contract. Freeman shall not be responsible for the performance of individuals of firms who are not under the direct supervision or control of Freeman. Freeman shall not be responsible for events or causes of loss, delay, or damage beyond its reasonable control, including (by way of illustration only, and not as a limitation on the breadth of this clause), strike, lockout, work slowdown or stoppage, power failure, breakdown of plant or machinery, facility failure, vandalism, theft, Act of God, effect of natural elements, riot, civil commotion or disturbance, terrorism, act of war or belligerent parties, and any other cause or causes beyond the reasonable control of Freeman. EXCEPT FOR ELIGIBLE GUARANTEED SERVICE SHIPMENTS, Freeman DOES NOT GUARANTEE DELIVERY BY ANY SPECIFIC TIME OR DATE.

4. PACKAGING AND CRATES: Shipper's property must be well packaged for safe and secure handling, storage and shipment using ordinary care. Each piece must be legibly and durably marked with the name and address, including correct ZIP code of the Shipper and Consignee. When a container is used repeatedly by Shipper, Shipper must remove all old labels, tags, markings, etc., and Shipper must ensure that the container retains adequate strength for transportation. Freeman makes neither representation nor any warranty regarding the acceptability or suitability of any packaging system or procedure that Shipper might use for its property. Freeman shall not be responsible for damage to loose or uncrated materials, padded or shrink-wrapped materials, glass breakage, concealed damage, carpets in bags or poly, or improperly packed or labeled materials. Crates and packaging should be of a design to adequately protect contents for handling by forklift and similar means. General guidance as to acceptable packaging systems and procedures may be found in publications such as the National Motor Freight Classification, published by the National Motor Freight Traffic Association. For shipments of Perishable Commodities, U.S. and Canadian shipments must be packed to travel without spoilage for 72 hours from time of pickup; all international shipments must be packed to travel without spoilage for 24 hours beyond an agreed deadline. Freeman reserves the right to periodically embargo regions of the world due to conditions that may cause damage to perishable commodities. If the integrity of a shipment is in question, Freeman reserves the right to improve packaging at shipper's expense.

5. REFUSED SHIPMENTS: If the Consignee refuses a shipment tendered for delivery or if Freeman is unable to deliver a shipment because of fault or mistake of the Consignor or Consignee, Freeman's liability shall then become that of a warehouseman.

- Freeman shall promptly attempt to provide notice, by telephonic, electronic or written communication as provided on the face of these shipping instructions, if so indicated, to Shipper or the party, if any, designated to receive notice in these instructions.
- Storage charges, based on Freeman's applicable rates, shall start no sooner than the next business day following the attempted notification. Storage may be, at Freeman's option, in any location that provides reasonable protection against loss or damage. Freeman may place the shipment in public storage at the owner's expense and without liability to Freeman.
- If Freeman does not receive disposition instructions within 48 hours of the time of Freeman's attempted first notification, Freeman will attempt to issue a second and final confirmed notification. Such notice shall advise that if Freeman does not receive disposition instructions within 10 days of that notification, Freeman may offer the shipment for sale at a public auction and Freeman has the right to offer the shipment for sale. The amount of sale will be applied to Freeman's invoice for transportation, storage and other lawful charges. Shipper will be responsible for the balance of charges not covered by the sale of the goods. If there is a balance remaining after all charges and expenses are paid, such balance will be paid to the owner of the property sold hereunder, upon claim and proof of ownership.
- Where Freeman has attempted to follow the procedure set forth above and the procedure is not possible, nothing shall be construed to abridge the right of Freeman, at its option, to sell the property under such circumstances and in such manner as may be authorized by law.
- When perishable goods cannot be delivered and disposition is not given within a reasonable time, Freeman may dispose of property to the best advantage. Where Freeman is directed by Consignee or Consignor to unload or deliver property at a particular location where Consignor, Consignee, or the Agent of either is not regularly located, Freeman's liability for the shipment shall terminate after unloading or delivery.

6. LIMITATION ON SHIPPER'S RECOVERABLE DAMAGES: FREEMAN'S LIABILITY FOR DAMAGES ON DOMESTIC SHIPMENTS, INCLUDING BUT NOT LIMITED TO THOSE DAMAGES ARISING FROM OR RELATED TO MISDELIVERY, INCOMPLETE OR OTHERWISE INADEQUATE DELIVERY (INCLUDING BUT NOT LIMITED TO FAILURE TO FOLLOW SHIPPER OR CONSIGNEE INSTRUCTIONS OR FAILURE TO COLLECT OR PROPERLY DELIVER A PAYMENT INSTRUMENT), NONDELIVERY, MISSED PICKUP, AND LOSS OF OR DAMAGE TO CARGO, SHALL BE LIMITED TO THE HIGHER OF \$50.00 (USD) PER SHIPMENT OR \$.50 (USD) PER POUND (\$1.10 (USD) PER KILOGRAM) OF CARGO ADVERSELY AFFECTED THEREBY, PLUS TRANSPORTATION CHARGES APPLICABLE TO THAT PART OF THE SHIPMENT ADVERSELY AFFECTED THEREBY, UNLESS AT TIME OF SHIPMENT THE SHIPPER MAKES A DECLARATION OF VALUE FOR CARRIAGE IN THE SPACE DESIGNATED ON THE SERVICE REQUEST AND SHIPPING INSTRUCTIONS FORM AND PAYS THE APPROPRIATE VALUATION CHARGE. IN NO EVENT SHALL FREEMAN'S LIABILITY EXCEED THE DECLARED VALUE OF THE SHIPMENT OR THE AMOUNT OF LOSS OR DAMAGE ACTUALLY SUSTAINED, WHICHEVER IS LOWER. IF CARRIAGE OF THE SHIPMENT IS SOLELY OR PARTLY BY AIR AND INVOLVES AN ULTIMATE DESTINATION OR A STOP IN A COUNTRY OTHER THAN THE COUNTRY OF DEPARTURE, Freeman's LIABILITY FOR CARGO LOST, DAMAGED OR DELAYED SHALL BE LIMITED TO \$9.07 PER POUND (\$20.00 PER KILOGRAM) FOR CARRIAGE SUBJECT TO THE UNAMENDED WARSAW CONVENTION OR THE WARSAW CONVENTION AS AMENDED BY THE HAGUE PROTOCOL OF 1955, 17 SPECIAL DRAWING RIGHTS PER KILOGRAM FOR CARRIAGE SUBJECT TO THE WARSAW CONVENTION AS AMENDED BY THE MONTREAL PROTOCOL NO. 4 OF 1975, OR \$9.07 PER POUND (\$20.00 PER KILOGRAM) FOR CARRIAGE WHERE THE WARSAW CONVENTION, INCLUDING ITS AMENDMENTS, DOES NOT APPLY FOR ANY REASON, UNLESS A HIGHER DECLARED VALUE IS REQUESTED, AND THE FEES SET FORTH IN THE SERVICE GUIDE FOR SUCH HIGHER DECLARED VALUE ARE PAID. FOR INTERNATIONAL SHIPMENTS, THIS SHIPPING REQUEST AND SHIPPING INSTRUCTION CONTRACT SHALL BE DEEMED AN AIR WAYBILL WITHIN THE MEANING OF THE WARSAW CONVENTION.

Notwithstanding the above limitations, domestic shipments containing the following items of extraordinary value are limited to a maximum declared value of \$500.00 (USD):

- artworks and objects of art, including without limitation original paintings, drawings, etchings, water colors, tapestries and sculpture;
 - clocks, watches, jewelry (including costume jewelry), furs and fur-trimmed clothing;
 - personal effects;
 - and other inherently fragile or unique items, including prototypes, etc.
- Any declared value in excess of the maximums allowed herein is null and void, and the acceptance by Freeman for carriage of any shipment with a declared value in excess of the allowed maximums does not constitute a waiver of these maximums. Shipper understands that even if Shipper is not able to participate or fully participate in a show due to loss of, theft of, or damage to its property, Freeman shall never be liable or responsible for damages identified by the terms (by way of example only and not in limitation of the breadth of this clause) such as the following: consequential damages, loss of use damages, loss of profits damages, business interruption damages, delay damages, special damages, collateral damages, exemplary damages, damages awarded for gross negligence, direct damages, indirect damages, damages for failure of performance, breach of contract damages, fraud damages, or any other sort of damage for tort or breach of contract. This limitation shall bind the parties:
- whenever or wherever the claimed loss or damage may occur;
 - even though the alleged loss or damage is claimed to result from negligence, strict liability, products liability, breach of contract, breach of statute or regulation, or any other legal theory or cause, and;
 - even though Freeman may have been advised or be on notice of the possibility or even the probability of such damages. Freeman makes no warranties, express or implied, and expressly disclaims any and all warranties. Except for Freeman's failure to deliver in accordance with the Guaranteed Service section of the Service Guide, Freeman will not be liable for misdelivery, incomplete or otherwise inadequate delivery (including but not limited to failure to follow Shipper or Consignee instructions or failure to collect or properly deliver a payment instrument), non-delivery, missed pickup, delay on International shipments, loss or damage unless caused by Freeman's sole negligence.

7. SHIPPER'S RESPONSIBILITIES AND INDEMNIFICATION:

- Shipper must pay in full for the services rendered under this Contract at the time the services are requested. The existence of a dispute between Shipper and Freeman relative to any claim or other matter shall have no bearing on this duty of payment. No claim submitted by or on behalf of Shipper will be processed unless Shipper's account is current.
- Shipper understands and acknowledges that Freeman does not accept or transport illegal, dangerous or hazardous materials of any kind or nature. Shipper warrants and ensures that its property is inert, and contains no Hazardous Substances, Hazardous Materials, Chemicals, Gases, Explosives, Radioactive Materials, Biologically Hazardous agents, or any other substance, matter or object in any form that could pose a threat to the health or safety of persons, property or the public welfare in general. Such goods may be warehoused at owner's risk and expense or destroyed without compensation.
- Shipper shall defend and indemnify Freeman, its employees, directors, officers, and agents from and against any and all demands, claims, causes of action, fines, penalties, damages (including consequential), liabilities, judgments, and expenses (including but not limited to reasonable attorneys' fees and investigation costs) on account of personal injury, death, or damage to or loss of property or profits arising out of or contributed to by any of the following: Shipper's negligence, willful misconduct, or deliberate act; Shipper's violation of Federal, State, County or Local ordinances; Shipper's violation of Show Regulations and/or Rules as published and set forth by Facility and/or Show Management; and/or Shipper's failure to comply with (b) of this Agreement regarding the inclusion of any dangerous substances in the property placed with Freeman.

8. CLAIMS: Shipper, Consignee, or any other party claiming an interest in the shipment must notify Freeman immediately upon delivery, or in the case of loss or damage which could not have been noted at the time of delivery, within five (5) business days of delivery, of any loss or damage to the shipment. Notice of concealed damage must be confirmed in writing or via email at exhibit.transportation@freeman.com within 5 business days of receipt of the property. If Carrier schedules an inspection, claimant must hold the shipping container, all packaging material and contents in the same condition as they were in when damage was discovered. Receipt of the shipment by the Consignee or the Consignee's agent without written notice on the delivery receipt and/or delivery manifest will be prima facie evidence that the shipment was delivered in good condition. The amount of the claim may not be deducted from the transportation charges. Notice of loss or damage MUST be reported to Freeman at 800-995-3579. The shipment, its container(s), and packing material must be made available to Freeman for inspection at the delivery location. All shipments are subject to opening for inspection by Freeman; however, Freeman is not obligated to perform such inspection. All claims for loss or damage MUST be made in writing to Freeman within one hundred and twenty (120) calendar days after the date of acceptance of the shipment by Freeman. Please refer to the Service Guide for claim procedures. All claims for service failure must be made within thirty (30) calendar days from the date of shipment and Freeman's sole liability for such claims arising from Guaranteed Service shipments shall be limited to the transportation charges as provided in the Guaranteed Service section of the Service Guide. All claims for overcharge must be made in writing to Freeman within sixty (60) calendar days after the invoice date. No claim for loss or damage may be maintained against Freeman unless (a) claimant complies with all requirements of this section and (b) for domestic shipments, if the claimant commences the action within one (1) year of the shipment by Freeman unless otherwise required by International, Federal or State Law. If the claim is for loss or damage involving International shipments, claimant must commence the action within two (2) years from the date of acceptance of the shipment by Freeman unless otherwise required by International, Federal or State Law. For purposes of this section, no action shall be deemed to have commenced until receipt by Freeman of service of process of the action on Freeman. Claims for loss or damage must be delivered to the following address: Sedgwick, PO Box 14151, Lexington, KY 40512-4151.

For shipping containers designed for repeated use (tradeshow cases, totes, crates), Freeman shall have no liability for superficial damage to said containers in the form of scuffs, scratches, dents or dings. Freeman will only accept liability for "catastrophic" damage to these shipping containers (crushing, puncture, or complete destruction). Freeman's maximum liability in cases of "catastrophic" damage or total loss will be limited to a depreciated value of the container based on the time elapsed from the original purchase and the purchase price established on the provided original invoice. This maximum liability will be subject to all other applicable limits of liability such as repair costs.

9. CHOICE OF FORUM: THIS CONTRACT SHALL BE CONSTRUED UNDER THE LAWS OF THE UNITED STATES (INCLUDING ADOPTED INTERNATIONAL CONVENTIONS) AND THE STATE OF TEXAS WITHOUT GIVING EFFECT TO THE STATE'S CONFLICT OF LAWS RULES. FREEMAN AND SHIPPER AGREE THAT ANY CLAIM OR DISPUTE OF ANY SORT ARISING OUT OF OR IN ANY WAY RELATED TO THIS CONTRACT, ITS PERFORMANCE OR NONPERFORMANCE, OR DAMAGES ALLEGEDLY RESULTING FROM SAME WILL BE ARBITRATED IN THE CITY OF DALLAS, TEXAS, AND THE RULES OF THE AMERICAN ARBITRATION ASSOCIATION WILL APPLY. IF BINDING ARBITRATION IS UNAVAILABLE TO RESOLVE ANY CONTROVERSY AND IT IS NECESSARY TO LITIGATE THE DISPUTE, THE DISPUTE SHALL BE LITIGATED IN A COURT OF COMPETENT JURISDICTION IN DALLAS COUNTY, TEXAS.

10. MISCELLANEOUS: Shipper warrants the accuracy of the weight and dimension data furnished in this Contract. Shipper understands that once its property is shipped by Freeman pursuant to the instructions contained in this Contract, Shipper has no right to control the shipment; stop the shipment in transit, or divert or reschedule same, and that Shipper will have no control over the property until it is delivered pursuant to the instructions in this Contract. Shipper agrees that this Contract may be provided to any third party, including common or contract carriers of cargo by air, water, rail, or road, for the purpose of confirming the right of Freeman to control the handling of the property and all matters related to payment for the shipment.

MOTOR CARGO

MOTOR CARGO SERVICE REQUEST AND SHIPPING INSTRUCTIONS CONTRACT

This Contract establishes your legal obligations with regard to the property described herein being shipped with Freeman Transportation. It specifically limits your rights and possible recovery if your property is lost or damaged. You must accept all terms and conditions of this Contract. You confirm that you have read and agree with all the terms and conditions of this Contract by receipt without contest. This Contract may not be waived or varied, except in writing, and then only by an authorized representative of Freeman.

1. DEFINITIONS. In this Contract, "Freeman" means Freeman Expositions, Inc., and its respective employees, officers, directors, agents, assigns, affiliated companies, and related entities including any contractors appointed by Freeman. The term "Shipper" means the person or business for whom the property is being transported, and includes their respective employees, officers, directors, agents, assigns, affiliated companies, and contractors appointed by the Shipper, excluding only Freeman. "Property" is all objects of any type received from the Shipper for transport by Freeman as described herein. "Consignee" is the party to whom Shipper has designated the goods are to be delivered.

2. FINAL CONTRACT BETWEEN THE PARTIES. In exchange for Shipper's payments and Freeman's services, which the parties have specified in this Contract, Freeman and Shipper each agree that this Contract shall govern their respective rights and obligations regarding transportation of Shipper's property. This Contract shall take effect when the property first comes into the physical possession of Freeman for inbound shipments and after loading on the applicable carrier for outbound shipments, and the responsibility of Freeman under same shall end when the property has been placed in the possession of the Consignee or the Consignee's designated agent. If any part or provision of this Contract is found by a court of competent jurisdiction to be void or unenforceable, the remainder of the Contract shall continue in full force and effect.

3. FREEMAN'S RESPONSIBILITIES UNDER THE CONTRACT ARE LIMITED. Freeman shall not be responsible for the performance of individuals or firms who are not under the direct supervision or control of Freeman. Freeman shall not be responsible for events or causes of loss, delay, or damage beyond its reasonable control, including (by way of illustration only, and not as a limitation on the breadth of this clause), strike, lockout, work slowdown or stoppage, power failure, breakdown of plant or machinery, facility failure, vandalism, theft, Act of God, effect of natural elements, riot, civil commotion or disturbance, terrorism, act of war or belligerent parties, and any other cause or causes beyond the reasonable control of Freeman. Freeman shall not be liable for delay caused by highway obstructions, or faulty or impassable highways, or lack of capacity of any highway, bridge, or ferry, or caused by breakdown or mechanical defects of vehicles or equipment, or from any cause other than the negligence of Freeman. Freeman shall not be bound to transport by any particular schedule, means, vehicle or otherwise, other than with reasonable dispatch.

4. PACKAGING AND CRATES. Shipper's property must be well packaged for safe and secure handling, storage and shipment using ordinary care. Freeman makes neither representation nor any warranty regarding the acceptability or suitability of any packaging system or procedure that Shipper might use for its property. Freeman shall not be responsible for damage to loose or uncrated materials, padwrapped or shrink-wrapped materials, glass breakage, concealed damage, carpets in bags or poly, or improperly packed or labeled materials. Crates and packaging should be of a design to adequately protect contents for handling by forklift and similar means. General guidance as to acceptable packaging systems and procedures may be found in publications such as the National Motor Freight Classification, published by the National Motor Freight Traffic Association. If the integrity of a shipment is in question, Freeman reserves the right to improve packaging at shipper's expense.

5. PERISHABLE GOODS. Goods of a perishable nature are carried in dry trailers without environmental or atmospheric control or other special services unless Shipper states on the face of the "Service Request and Shipping Instructions" that the goods are to be carried in a refrigerated, heated, specially ventilated or otherwise specially equipped trailer. This carriage may be subject to additional charges. Shipper is responsible for bringing the goods to the proper temperature before loading the goods into the trailer, for the proper stowage of the goods within the trailer, and for setting the temperature (including maintenance and repair), during all times after the trailer is spotted by Freeman and before the trailer is received by Freeman. Freeman is not responsible for product deterioration caused by inherent vice, defects in the merchandise or transit times in excess of product shelf life. Refrigerated, heated, specially ventilated or otherwise specially equipped trailers are not equipped to change the temperature of goods (they are equipped only to maintain temperature). Shipper will give written notice of requested temperature setting of the thermostatic controls before receipt of the goods by Freeman. When a loaded trailer is received, Freeman will verify that the thermostatic controls are set to maintain trailer temperature as requested. Freeman is unable to determine whether the goods were at the proper temperature when they were loaded into the trailer or when the trailer is delivered to Freeman. Air temperature at the unit sensor will be maintained within a proper range of plus or minus 5 degrees Fahrenheit of the temperature requested by Shipper on the face of the "Service Request and Shipping Instructions" if the goods were at that temperature when loaded into the container and if the temperature controls were properly set when the container was loaded.

6. REFUSED SHIPMENTS. If the Consignee refuses a shipment tendered for delivery or if Freeman is unable to deliver a shipment because of fault or mistake of Freeman, Freeman's liability shall then become that of a warehouseman.

(a) Freeman shall promptly attempt to provide notice, by telephonic, electronic or written communication as provided on the face of these shipping instructions, if so indicated, to Shipper or the party, if any, designated in these instructions to receive notice.

(b) Storage charges, if applicable, shall start no sooner than the next business day following the attempted notification. Storage may be, at Freeman's option, in any location that provides reasonable protection against loss or damage. Freeman may place the shipment in public storage at the owner's expense and without liability to Freeman.

(c) If Freeman does not receive disposition instructions within 48 hours of the time of Freeman's attempted first notification, Freeman will attempt to issue a second and final confirmed notification. Such notice shall advise that if Freeman does not receive disposition instructions within 10 days of that notification, Freeman may offer the shipment for sale at a public auction and Freeman has the right to offer the shipment for sale. The amount of sale will be applied to Freeman's invoice for transportation, storage and other lawful charges. Shipper will be responsible for the balance of charges not covered by the sale of the goods. If there is a balance remaining after all charges and expenses are paid, such balance will be paid to the owner of the property sold hereunder, upon claim and proof of ownership.

(d) Where Freeman has attempted to follow the procedure set forth above and the procedure is not possible, nothing shall be construed to abridge the right of Freeman, at its option, to sell the property under such circumstances and in such manner as may be authorized by law.

(e) When perishable goods cannot be delivered and disposition is not given within a reasonable time, Freeman may dispose of property to the best advantage. When Freeman is directed by Consignee or Consignor to unload or deliver property at a particular location where Consignor, Consignee, or the Agent of either is not regularly located, Freeman's liability for the shipment shall terminate after unloading or delivery.

7. INSURANCE. Freeman IS NOT AN INSURER. Shipper is responsible for obtaining insurance for its property. Freeman provides no insurance for Shipper or its property.

8. LIMITATION ON SHIPPER'S RECOVERABLE DAMAGES. Shipper understands that even if shipper's property is lost, stolen, or damaged, Freeman does not pay replacement or restoration cost of any property. **FREEMAN'S MAXIMUM LIABILITY SHALL BE THE AMOUNT OF PROVEN ACTUAL VALUE NOT EXCEEDING THE LOWER OF FAIR MARKET VALUE.**

(THE "FAIR MARKET VALUE" EQUALS THE AS IS WHERE IS PRICE FOR THE PROPERTY AT THE LOCATION OF THE SHOW TO WHICH PRICE A WILLING BUYER AND A WILLING SELLER WOULD AGREE IN AN ORDINARY COURSE OF BUSINESS, ARM'S LENGTH SALE.) OR \$5.00 (USD) PER POUND OF CARGO LOST OR DAMAGED UNLESS AT THE TIME OF SHIPMENT SHIPPER MAKES A DECLARATION OF VALUE FOR CARRIAGE IN THE SPACE DESIGNATED ON THE SHIPPING INSTRUCTIONS AND PAYS THE APPROPRIATE VALUATION CHARGE. Even if Shipper has made a declaration of value, liability shall never exceed the depreciated original invoice value or the fair market value of the property, whichever is less. The value per pound for applying declared valuation charges shall be determined by dividing Shipper's declared value for carriage by the actual weight of the shipment. In all cases not prohibited by law, where a lower value than the actual value of the said property has been stated in writing by Shipper or has been agreed upon in writing as the released value of the property upon which the rate is based, such lower value plus freight charges, if paid, shall be the maximum recoverable amount for loss or damage. **Notwithstanding the above limitations, all shipments containing the following items of extraordinary value are limited to a maximum declared value of \$500.00 (USD):** (a) Artworks and objects of art, including without limitation, original paintings, drawings, etchings, watercolors, tapestries and sculptures or prototypes; (b) Clocks, jewelry, including costume jewelry, furs, and fur-trimmed clothing; (c) Personal effects, including without limitation, papers and documents; or (d) Coin money, currency, gift certificates, debit cards, credit cards, and any other items of extraordinary value. (e) For either unmarked, unlabeled, or improperly packaged television monitors, the maximum liability is the lesser of \$3.00 (USD) per pound or the actual invoice price.

Any declared value in excess of the maximums allowed herein is null and void, and the acceptance by Freeman for carriage of any shipment with a declared value in excess of the allowed maximums does not constitute a waiver of these maximums. In any event, (excluding small package program shipments) **Freeman's MAXIMUM LIABILITY WILL NEVER BE MORE THAN \$100,000 PER SHIPMENT.** Shipper understands that even if Shipper is not able to participate or fully participate in a Show due to loss of, theft of, or damage to their property, Freeman shall not be liable or responsible for damages identified by the terms (by way of example only and not in limitation of the breadth of this clause) such as the following: consequential damages, loss of use damages, loss of profits damages, business interruption damages, delay damages, special damages, collateral damages, exemplary damages, damages awarded for gross negligence, direct damages, indirect damages, or damages for failure of performance, breach of contract damages, fraud damages, or any other sort of damage for tort or breach of contract. This limitation shall bind the parties: **(a) WHENEVER OR WHEREVER THE CLAIMED LOSS OR DAMAGE MAY OCCUR; (b) EVEN THOUGH THE ALLEGED LOSS OR DAMAGE IS CLAIMED TO RESULT FROM NEGLIGENCE, STRICT LIABILITY, PRODUCTS LIABILITY, BREACH OF CONTRACT, BREACH OF STATUTE OR REGULATION, OR ANY OTHER LEGAL THEORY OR CAUSE, AND; (c) EVEN THOUGH FREEMAN MAY HAVE BEEN ADVISED OR BE ON NOTICE OF THE POSSIBILITY OR EVEN THE PROBABILITY OF SUCH DAMAGES.**

9. SHIPPER'S RESPONSIBILITIES AND INDEMNIFICATION:

(a) Shipper must pay in full for the services rendered under this Agreement at the time the services are requested. The existence of a dispute between Shipper and Freeman relative to any claim or other matter shall have no bearing on this duty of payment. No claim may be submitted by or on behalf of Shipper to Freeman unless Shipper's account is current.

(b) Shipper understands and acknowledges that Freeman does not accept or transport illegal or hazardous materials of any kind or nature. Shipper warrants and will ensure that its property is inert, and contains no Hazardous Substances, Hazardous Materials, Chemicals, Gasses, Explosives, Radioactive Materials, Biologically hazardous agents, or any other substance, matter or object in any form that could pose a threat to the health or safety of Freeman persons, property, or the public welfare in general. Such goods may be warehoused at owner's risk and expense or destroyed without compensation.

(c) Shipper shall defend and indemnify Freeman, its employees, directors, officers, and agents from and against any and all demands, claims, causes of action, fines, penalties, damages (including consequential), liabilities, judgments, and expenses (including but not limited to reasonable attorneys' fees and investigation costs) on account of personal injury, death, or damage to or loss of property or profits arising out of or contributed to by any of the following: Shipper's negligence, willful misconduct, or deliberate act; Shipper's violation of Federal, State, County or Local ordinances; Shipper's violation of Show Regulations and/or Rules as published and set forth by Facility and/or Show Management; and/or Shipper's failure to comply with subsection (b) of this section regarding the inclusion of any dangerous substances in the property placed with Freeman.

10. CLAIMS. Claims must be filed in writing within nine (9) months after the date of delivery of the property (or in the case of export traffic, within nine (9) months after delivery at the port of export), except that claims for failure to make delivery must be filed within nine (9) months after a reasonable time for delivery has elapsed. Suits for loss, damage, or delay shall be instituted against Freeman no later than two (2) years and one (1) day from the day when written notice is given by Freeman to the claimant that Freeman has disallowed the claim or any part or parts of the claim specified in the notice. Shipper shall deliver notice of claim for loss or damage by hand, U.S. mail, courier, facsimile, or electronic means to Sedgwick, PO Box 14151, Lexington, KY 40512-4151 as soon as loss or damage is discovered. The notice of claim shall invite a prompt joint survey of the damage, at a time and place to be agreed between the parties, and such survey shall go forward promptly. However, if in any case the property is received by the Consignee or the Consignee's agent without notice of loss or damage to property being served on Freeman within 5 business days of the receipt of the property, it is agreed between Freeman and Shipper that in that instance the presumption shall arise that the property was delivered in proper quantity and in good condition. Notice of concealed damage must be confirmed in writing or via email at exhibit.transportation@freeman.com within 5 business days of receipt of the property. If Carrier schedules an inspection, claimant must hold the shipping container, all packaging material and contents in the same condition as they were in when damage was discovered. Claims filed more than nine (9) months following the date on which the property was delivered or should have been delivered are agreed to be forever time barred.

For shipping containers designed for repeated use (tradeshow cases, totes, crates), Freeman shall have no liability for superficial damage to said containers in the form of scuffs, scratches, dents or dings. Freeman will only accept liability for "catastrophic" damage to these shipping containers (crushing, puncture, or complete destruction). Freeman's maximum liability in cases of "catastrophic" damage or total loss will be limited to a depreciated value of the container based on the time elapsed from the original purchase and the purchase price established on the provided original invoice. This maximum liability will be subject to all other applicable limits of liability such as repair costs.

11. CHOICE OF FORUM / ARBITRATION. THIS CONTRACT SHALL BE CONSTRUED UNDER THE LAWS OF THE STATE OF TEXAS WITHOUT GIVING EFFECT TO ITS CONFLICT OF LAWS RULES. EXCLUSIVE VENUE FOR ALL DISPUTES ARISING OUT OF CONTRACT, TORT, COMMON LAW OR RELATING TO THE ENFORCEMENT OR INTERPRETATION OF THIS CONTRACT SHALL RESIDE IN A COURT OF COMPETENT JURISDICTION IN DALLAS COUNTY, TEXAS. Notwithstanding anything herein to the contrary, any controversy or claim arising out of or relating to this Agreement, or the breach thereof, shall be exclusively settled by arbitration administered by the American Arbitration Association in accordance with its Commercial Arbitration Rules and judgment on the award rendered by the arbitrator(s) may be entered by any court having jurisdiction thereof.

12. MISCELLANEOUS. (a) Shipper warrants the accuracy of the weight and dimension data furnished in this Contract; (b) Shipper understands that once its property is shipped by Freeman pursuant to the instructions contained in this Contract, Shipper has no right to control the shipment, stop the shipment in transit, or divert or reschedule same. (c) Shipper agrees that this Contract may be provided to any third party, including common or contract carriers of cargo by air, water, rail, or road, for the purpose of confirming the right of Freeman to control the handling of the property and all matters related to payment for the shipment. Shipper agrees that all shipments are subject to correction and final charges determined by the actual or re-weighed weight of the shipment.

13. SMALL PACKAGE PROGRAM. If items shipped via Freeman's Small Packages program are lost, damaged or destroyed while in Freeman's possession, **FREEMAN'S MAXIMUM LIABILITY SHALL BE \$100 per package UNLESS AT THE TIME OF SHIPMENT SHIPPER MAKES A DECLARATION OF VALUE IN THE SPACE DESIGNATED ON THE SHIPPING INSTRUCTIONS AND PAYS THE APPROPRIATE VALUATION CHARGE.** If small packages are received by the Shipper and notice of loss or damage is not received by Freeman within 15 days of the delivery of the property, the parties agree that the presumption shall arise that the property was delivered in proper quantity and in good condition.

FREEMAN

8201 West 47th St
 Mc Cook, IL 60525
 (773) 473-7080 Fax: (469) 621-5603
 FreemanChicagoES@freeman.com

**ONLINE PRICE
 DISCOUNT PRICE
 DEADLINE DATE
 MARCH 12, 2020**

NAME OF SHOW: **NECANN - ILLINOIS CANNABIS CONVENTION / APRIL 3 - 4, 2020**

COMPANY NAME: _____ BOOTH #: _____ BOOTH SIZE: **X**

CONTACT NAME : _____ PHONE #: _____

E-MAIL ADDRESS : _____

For Assistance, please call (773) 473-7080 to speak with one of our experts.

For fast, easy ordering, go to www.freeman.com/store

Qty	Part #	Description	Online Price	Discount Price	Standard Price	Total
-----	--------	-------------	--------------	----------------	----------------	-------

SOFT SEATING

Naples Group - Black Vinyl

_____	810119	Chair.....	374.30	411.75	524.00	_____
_____	830120	Loveseat.....	503.50	553.85	704.90	_____
_____	830119	Sofa.....	558.60	614.45	782.05	_____

Munich Group - Gray Fabric

_____	810150	Corner Chair.....	457.90	503.70	641.05	_____
_____	810151	Armless Chair.....	399.00	438.90	558.60	_____
_____	830200	Armless Loveseat.....	670.70	737.75	939.00	_____
_____	830201	Sectional - 3 Piece.....	1,527.60	1,680.35	2,138.65	_____

Baja Group - White Vinyl

_____	81050	Chair.....	456.00	501.60	638.40	_____
_____	83020	Loveseat.....	484.50	532.95	678.30	_____
_____	83019	Sofa.....	636.50	700.15	891.10	_____

Valencia - Velvet

_____	810180	Chair - Spice Orange.....	245.80	270.40	344.10	_____
_____	83045	Sofa - Coffee Brown.....	369.30	406.25	517.00	_____

Key Largo Group - Black Fabric

_____	830950	Loveseat.....	389.50	428.45	545.30	_____
_____	830951	Sofa.....	433.20	476.50	606.50	_____
_____	810950	Chair.....	307.80	338.60	430.90	_____

Allegro Group - Blue Fabric

_____	81019	Chair.....	380.00	418.00	532.00	_____
_____	83015	Sofa.....	604.20	664.60	845.90	_____

Fairfax Group - White Vinyl

_____	810949	Chair.....	260.30	286.35	364.40	_____
_____	830949	Sofa.....	414.20	455.60	579.90	_____

Palm Beach - White Vinyl

_____	83040	Sofa.....	488.30	537.15	683.60	_____
-------	-------	-----------	--------	--------	--------	-------

Tangiers Group - Beige Fabric

_____	810118	Chair.....	330.60	363.65	462.85	_____
_____	830220	Loveseat.....	564.30	620.75	790.00	_____
_____	830118	Sofa.....	467.40	514.15	654.35	_____

CASUAL SEATING

Ottomans

_____	815122	Endless Square - White Vinyl.....	239.40	263.35	335.15	_____
_____	815123	Endless Square - Black Vinyl.....	239.40	263.35	335.15	_____
_____	815953	Endless Curve - White Vinyl.....	321.10	353.20	449.55	_____
_____	815952	Endless Curve - Black Vinyl.....	321.10	353.20	449.55	_____
_____	815119	Half-Bench - White Vinyl.....	273.60	300.95	383.05	_____
_____	81518	Vibe Cube - Blue Vinyl.....	108.30	119.15	151.60	_____
_____	81519	Vibe Cube - Red Vinyl.....	108.30	119.15	151.60	_____

NAME OF SHOW: **NECANN - ILLINOIS CANNABIS CONVENTION / APRIL 3 - 4, 2020**

COMPANY NAME: _____ BOOTH #: _____ BOOTH SIZE: X

CONTACT NAME : _____ PHONE #: _____

E-MAIL ADDRESS : _____

For Assistance, please call (773) 473-7080 to speak with one of our experts.

For fast, easy ordering, go to www.freeman.com/store

Qty	Part #	Description	Online Price	Discount Price	Standard Price	Total
Ottomans (continued)						
_____	81525	Vibe Cube - Orange Vinyl.....	108.30	119.15	151.60	_____
_____	81517	Vibe Cube - Yellow Vinyl.....	108.30	119.15	151.60	_____
_____	81530	Vibe Cube - Black Vinyl.....	95.00	104.50	133.00	_____
_____	81531	Vibe Cube - White Vinyl.....	95.00	104.50	133.00	_____
_____	81532	Vibe Cube - Steel Blue Vinyl.....	108.30	119.15	151.60	_____
_____	81533	Vibe Cube - Silver Vinyl.....	108.30	119.15	151.60	_____
_____	81534	Vibe Cube - Purple Vinyl.....	108.30	119.15	151.60	_____
_____	81535	Vibe Cube -Citrus Green Vinyl.....	108.30	119.15	151.60	_____
_____	81536	Vibe Cube - Taupe Vinyl.....	108.30	119.15	151.60	_____
_____	81537	Vibe Cube - Spice Orange Vinyl.....	108.30	119.15	151.60	_____
_____	81538	Vibe Cube - Desert Rose Vinyl.....	108.30	119.15	151.60	_____
_____	815151	Marche Swivel - Gray Fabric.....	169.10	186.00	236.75	_____
_____	815154	Marche Swivel - Red Fabric.....	169.10	186.00	236.75	_____
_____	815159	Marche Swivel - Blue Fabric.....	169.10	186.00	236.75	_____
_____	815152	Marche Swivel - Linen Fabric.....	169.10	186.00	236.75	_____
_____	815157	Marche Swivel - Meadow Green Fabric.....	169.10	186.00	236.75	_____
_____	815158	Marche Swivel - Pear Yellow Fabric.....	169.10	186.00	236.75	_____
_____	815156	Marche Swivel - Plum Fabric.....	169.10	186.00	236.75	_____
_____	815153	Marche Swivel - Raspberry Fabric.....	169.10	186.00	236.75	_____
_____	815155	Marche Swivel - Rose Quartz Fabric.....	169.10	186.00	236.75	_____
_____	815150	Marche Swivel - White Vinyl.....	169.10	186.00	236.75	_____
_____	815160	Marche Swivel - Orange Fabric.....	169.10	186.00	236.75	_____
_____	81540	Marche Swivel - Forest Green Vinyl.....	169.10	186.00	236.75	_____
_____	81541	Marche Swivel - Teal Velvet.....	169.10	186.00	236.75	_____
_____	81542	Marche Swivel - Distressed Brown Vinyl.....	169.10	186.00	236.75	_____
_____	81543	Marche Swivel - Black Vinyl.....	169.10	186.00	236.75	_____
_____	81526	Edge LED Cube - High Density Plastic.....	152.00	167.20	212.80	_____
Banquettes						
_____	8506	Center Cone w/Electrical Charging Outlet.....	452.20	497.40	633.10	_____
_____	8507	Quarter Curve Ottoman.....	298.30	328.15	417.60	_____
Beverly Bench Ottomans						
_____	81550	Black Vinyl.....	340.10	374.10	476.15	_____
_____	81551	Brown Fabric.....	340.10	374.10	476.15	_____
_____	81552	Gray Fabric.....	340.10	374.10	476.15	_____
_____	81553	Linen Fabric.....	340.10	374.10	476.15	_____
_____	81554	Ocean Blue Fabric.....	340.10	374.10	476.15	_____
_____	81555	Red Fabric.....	340.10	374.10	476.15	_____
_____	81556	White Vinyl.....	340.10	374.10	476.15	_____
Accent Chairs						
_____	71089	Black Diamond Side Chair.....	196.60	216.25	275.25	_____
_____	71090	Black Diamond Arm Chair.....	248.50	273.35	347.90	_____
_____	810861	Laguna Chair - Maple/Chrome.....	104.50	114.95	146.30	_____
_____	210108	Limerick® Chair by Herman Miller.....	140.10	154.10	196.15	_____

FREEMAN furnishings

Take advantage of the Online price
by ordering at www.freeman.com before
MARCH 12, 2020

NAME OF SHOW: **NECANN - ILLINOIS CANNABIS CONVENTION / APRIL 3 - 4, 2020**

COMPANY NAME: _____ BOOTH #: _____ BOOTH SIZE: X

CONTACT NAME : _____ PHONE #: _____

E-MAIL ADDRESS : _____

For Assistance, please call (773) 473-7080 to speak with one of our experts.

For fast, easy ordering, go to www.freeman.com/store

Qty	Part #	Description	Online Price	Discount Price	Standard Price	Total
Accent Chairs (continued)						
	810816	Madrid Chair - White Vinyl/Chrome.....	571.90	629.10	800.65	
	810948	Meeting Chair - White Vinyl.....	180.50	198.55	252.70	
	810835	Meeting Chair - Espresso Vinyl.....	140.60	154.65	196.85	
	810836	Meeting Chair - Taupe Microfiber.....	182.40	200.65	255.35	
	8103	Key West Tub Chair - Black Fabric.....	304.00	334.40	425.60	
	810164	Marina Chair - White Vinyl.....	112.10	123.30	156.95	
	810160	Marina Chair - Black Vinyl.....	112.10	123.30	156.95	
	810161	Marina Chair - Brown Fabric.....	112.10	123.30	156.95	
	810162	Marina Chair - Ocean Blue Fabric.....	112.10	123.30	156.95	
	810163	Marina Chair - Red Fabric.....	112.10	123.30	156.95	
	810131	Malba Chair - Gray Molded Plastic.....	76.00	83.60	106.40	
	810130	Malba Chair - Green Molded Plastic.....	74.10	81.50	103.75	
	810846	Christopher Chair - White Vinyl/Chrome.....	93.10	102.40	130.35	
	810851	Zenith Chair - White/Chrome.....	117.80	129.60	164.90	
	810841	Rustique Chair - Gunmetal.....	74.10	81.50	103.75	
	810837	Razor Armless Chair - White High Density Plastic.....	43.70	48.05	61.20	
	810875	Swanson Swivel Chair - White Vinyl.....	262.20	288.40	367.10	
	81083	Blade Chair - Sky Blue.....	60.80	66.90	85.10	
	81082	Blade Chair - Red.....	60.80	66.90	85.10	
	810810	Berlin Stack Chair - White & Black Plastic/Chrome...	83.60	91.95	117.05	
	81093	Lucent Chair - Frosted Acrylic.....	157.70	173.45	220.80	
	810145	Wentworth Chair - Brown Vinyl.....	256.50	282.15	359.10	
Executive Seating						
	71046	Gray Gaslift Chair With Arms.....	382.85	421.15	536.00	
	71045	Gray Gaslift Chair Without Arms.....	360.55	396.60	504.75	
	810874	La Brea Swivel Chair - Charcoal Gray Fabric.....	239.40	263.35	335.15	
	810175	Genesis Chair - Black.....	122.30	134.55	171.20	
	810844	Pro Executive High Back Chair - White Vinyl.....	209.00	229.90	292.60	
	810946	Pro Executive High Back Chair - Black Vinyl.....	209.00	229.90	292.60	
	810945	Pro Executive Mid Back Chair - White Vinyl.....	266.00	292.60	372.40	
	810944	Pro Executive Mid Back Chair - Black Vinyl.....	266.00	292.60	372.40	
	810947	Pro Executive Guest Chair - Black Vinyl.....	275.50	303.05	385.70	
	810170	Cupertino Mid Back Chair - Black Vinyl.....	196.40	216.05	274.95	
Barstools						
	71088	Black Diamond Stool.....	313.45	344.80	438.85	
	71048	Gray Gaslift Stool with Arms.....	526.75	579.45	737.45	
	71047	Gray Gaslift Stool without Arms.....	462.85	509.15	648.00	
	810860	Laguna Barstool - Maple/Chrome.....	131.10	144.20	183.55	
	210109	Limerick® Stool by Herman Miller.....	196.90	216.60	275.65	
	810872	Lift Barstool - Gray Vinyl/Chrome.....	123.50	135.85	172.90	
	810873	Lift Barstool - Red Vinyl/Chrome.....	123.50	135.85	172.90	
	810871	Lift Barstool - Black Vinyl/Chrome.....	123.50	135.85	172.90	
	810870	Lift Barstool - White Vinyl/Chrome.....	123.50	135.85	172.90	
	810951	Apex Barstool - Black Vinyl.....	153.90	169.30	215.45	
	810952	Apex Barstool - Blue Ultra Suede.....	153.90	169.30	215.45	
	810953	Apex Barstool - Red Vinyl.....	153.90	169.30	215.45	
	810954	Apex Barstool - White Vinyl.....	153.90	169.30	215.45	
	810103	Banana Barstool - White Vinyl/Chrome.....	146.30	160.95	204.80	

FREEMAN furnishings

Take advantage of the Online price
by ordering at www.freeman.com before
MARCH 12, 2020

NAME OF SHOW: **NECANN - ILLINOIS CANNABIS CONVENTION / APRIL 3 - 4, 2020**

COMPANY NAME: _____ BOOTH #: _____ BOOTH SIZE: **X**

CONTACT NAME : _____ PHONE #: _____

E-MAIL ADDRESS : _____

For Assistance, please call (773) 473-7080 to speak with one of our experts.

For fast, easy ordering, go to www.freeman.com/store

Qty	Part #	Description	Online Price	Discount Price	Standard Price	Total
Barstools (continued)						
	810104	Banana Barstool - Black Vinyl/Chrome.....	146.30	160.95	204.80	
	810850	Zenith Barstool - White/Chrome.....	117.80	129.60	164.90	
	810840	Zoey Barstool - White Vinyl/Chrome.....	228.00	250.80	319.20	
	810834	Zoey Barstool - Black Vinyl/Chrome.....	228.00	250.80	319.20	
	810848	Christopher Barstool - White Vinyl/Chrome.....	159.60	175.55	223.45	
	810202	Shark Swivel Barstool - White Plastic/Chrome.....	252.70	277.95	353.80	
	810839	Rustique Barstool - Gunmetal.....	81.70	89.85	114.40	
	810201	Oslo Barstool - White Plastic/Chrome.....	182.40	200.65	255.35	
	81080	Blade Barstool - Red.....	123.50	135.85	172.90	
	81081	Blade Barstool - Sky Blue.....	123.50	135.85	172.90	
	81092	Lucent Barstool - Frosted Acrylic.....	167.20	183.90	234.10	
	810135	Task Stool - Black Fabric.....	134.90	148.40	188.85	

Draped Tables & Counters

Draped Tables - Tables are 24" wide					
<input type="checkbox"/> Black	<input type="checkbox"/> Blue	<input type="checkbox"/> Brown	<input type="checkbox"/> Green	<input type="checkbox"/> Flax	
<input type="checkbox"/> Gold	<input type="checkbox"/> Gray	<input type="checkbox"/> Plum	<input type="checkbox"/> Red	<input type="checkbox"/> White	

	124330	Draped Table 3'L x 30"H.....	141.40	155.55	197.95	
	124430	Draped Table 4'L x 30"H.....	181.65	199.80	254.30	
	124630	Draped Table 6'L x 30"H.....	233.25	256.60	326.55	
	124830	Draped Table 8'L x 30"H.....	282.35	310.60	395.30	
	12404630	4th Side Drape 6'L x 30"H.....	58.00	63.80	81.20	
	12404830	4th Side Drape 8'L x 30"H.....	58.00	63.80	81.20	
	124342	Draped Counter 3'L x 42"H.....	191.95	211.15	268.75	
	124442	Draped Counter 4'L x 42"H.....	227.00	249.70	317.80	
	124642	Draped Counter 6'L x 42"H.....	280.50	308.55	392.70	
	124842	Draped Counter 8'L x 42"H.....	325.05	357.55	455.05	
	12404642	4th Side Drape 6'L x 42"H.....	76.90	84.60	107.65	
	12404842	4th Side Drape 8'L x 42"H.....	76.90	84.60	107.65	

Undraped Tables & Counters

	125330	Undraped Table 3'L x 30"H.....	52.85	58.15	74.00	
	125430	Undraped Table 4'L x 30"H.....	61.15	67.25	85.60	
	125630	Undraped Table 6'L x 30"H.....	81.25	89.40	113.75	
	125830	Undraped Table 8'L x 30"H.....	96.30	105.95	134.80	
	125342	Undraped Counter 3'L x 42"H.....	96.30	105.95	134.80	
	125442	Undraped Counter 4'L x 42"H.....	103.80	114.20	145.30	
	125642	Undraped Counter 6'L x 42"H.....	122.50	134.75	171.50	
	125842	Undraped Counter 8'L x 42"H.....	138.90	152.80	194.45	

Table Top Risers - Risers are 8" wide

	1504100	Black 4'L x 7"H Corrugated Riser.....	29.25	32.20	40.95	
	1504101	White 4'L x 7"H Corrugated Riser.....	29.25	32.20	40.95	
	1506100	Black 6'L x 7"H Corrugated Riser.....	34.25	37.70	47.95	
	1506101	White 6'L x 7"H Corrugated Riser.....	34.25	37.70	47.95	
	1508100	Black 8'L x 7"H Corrugated Riser.....	39.50	43.45	55.30	
	1508101	White 8'L x 7"H Corrugated Riser.....	39.50	43.45	55.30	
	1504200	Black 4'L x 14"H Corrugated Riser.....	44.75	49.25	62.65	
	1504201	White 4'L x 14"H Corrugated Riser.....	44.75	49.25	62.65	
	1506200	Black 6'L x 14"H Corrugated Riser.....	54.75	60.25	76.65	

FREEMAN furnishings

Take advantage of the Online price
by ordering at www.freeman.com before
MARCH 12, 2020

NAME OF SHOW: **NECANN - ILLINOIS CANNABIS CONVENTION / APRIL 3 - 4, 2020**

COMPANY NAME: _____ BOOTH #: _____ BOOTH SIZE: **X**

CONTACT NAME : _____ PHONE #: _____

E-MAIL ADDRESS : _____

For Assistance, please call (773) 473-7080 to speak with one of our experts.

For fast, easy ordering, go to www.freeman.com/store

Qty	Part #	Description	Online Price	Discount Price	Standard Price	Total
Table Top Risers - Risers are 8" wide (continued)						
	1506201	White 6'L x 14"H Corrugated Riser.....	54.75	60.25	76.65	
	1508200	Black 8'L x 14"H Corrugated Riser.....	64.75	71.25	90.65	
	1508201	White 8'L x 14"H Corrugated Riser.....	64.75	71.25	90.65	
Pedestal Tables - Soho Series						
	72069	Black Top Cafe Table - 30"H x 24"W.....	288.45	317.30	403.85	
	72067	Black Top Cafe Table - 30"H x 36"W.....	296.70	326.35	415.40	
	72066	Black Top Mini Table - 18"H x 18"W.....	157.95	173.75	221.15	
	72070	Black Top Bistro Table - 42"H x 24"W.....	315.00	346.50	441.00	
	72068	Black Top Bistro Table - 42"H x 36"W.....	323.80	356.20	453.30	
Pedestal Tables - Chelsea Series						
	72063	Butcher Block Top Cafe Table - 30"H x 30"W.....	296.70	326.35	415.40	
	72064	Butcher Block Top Cafe Table - 30"H x 36"W.....	296.70	326.35	415.40	
	720163	Butcher Block Top Bistro Table - 42"H x 30"W.....	323.80	356.20	453.30	
	720164	Butcher Block Top Bistro Table - 42"H x 36"W.....	323.80	356.20	453.30	
Pedestal Tables						
	8201208	Hydraulic Base Cafe Table - Maple.....	264.10	290.50	369.75	
	8201207	Hydraulic Base Bar Table - Maple.....	275.50	303.05	385.70	
	8201209	Hydraulic Base Cafe Table - Graphite.....	294.50	323.95	412.30	
	8201211	Hydraulic Base Bar Table - Graphite.....	302.10	332.30	422.95	
	8201206	Hydraulic Base Cafe Table - Maple.....	300.20	330.20	420.30	
	8201205	Hydraulic Base Bar Table - Maple.....	296.40	326.05	414.95	
	820126	Hydraulic Base Cafe Table - White Laminate.....	300.20	330.20	420.30	
	820125	Hydraulic Base Bar Table - White Laminate.....	313.50	344.85	438.90	
	820241	Madison Hydraulic Base Cafe Table - Gray Acajou.	235.60	259.15	329.85	
	820240	Madison Hydraulic Base Bar Table - Gray Acajou...	235.60	259.15	329.85	
	820265	Madison Cafe Table - Gray Acajou.....	186.20	204.80	260.70	
	820264	Madison Bar Table - Gray Acajou.....	203.30	223.65	284.60	
	8201220	30" Cafe Table Black Base - White Laminate.....	197.60	217.35	276.65	
	8201221	30" Bar Table Black Base - White Laminate.....	212.80	234.10	297.90	
	8201222	30" Bar Table Chrome Base - White Laminate.....	304.00	334.40	425.60	
	8201223	30" Cafe Table Chrome Base - White Laminate.....	304.00	334.40	425.60	
	820920	30" Bar Table Chrome Hydraulic Base - Red.....	235.60	259.15	329.85	
	820921	30" Cafe Table Chrome Hydraulic Base - Red.....	235.60	259.15	329.85	
	820922	30" Bar Table Chrome Hydraulic Base - Graphite.....	235.60	259.15	329.85	
	820923	30" Cafe Table Chrome Hydraulic Base - Graphite....	235.60	259.15	329.85	
	820930	30" Bar Table w/ Hydraulic Base - Blue.....	229.90	252.90	321.85	
	820931	30" Bar Table w/ Black Base - Blue.....	182.40	200.65	255.35	
	820932	30" Bar Table w/ Hydraulic Base - Wood.....	281.20	309.30	393.70	
	820933	30" Bar Table w/ Black Base - Wood.....	188.10	206.90	263.35	
	820940	30" Cafe Table w/ Hydraulic Base - Blue.....	229.90	252.90	321.85	
	820941	30" Cafe Table w/ Black Base - Blue.....	140.60	154.65	196.85	
	820942	30" Cafe Table w/ Hydraulic Base - Wood.....	281.20	309.30	393.70	
	820943	30" Cafe Table w/ Black Base - Wood.....	178.60	196.45	250.05	
	820910	30" Bar Table w/ Hydraulic Base - Gunmetal.....	304.00	334.40	425.60	
	820911	30" Bar Table w/ Hydraulic Base - Black.....	304.00	334.40	425.60	

FREEMAN furnishings

Take advantage of the Online price
by ordering at www.freeman.com before
MARCH 12, 2020

COMPANY NAME: _____ BOOTH #: _____ BOOTH SIZE: X

CONTACT NAME : _____ PHONE #: _____

E-MAIL ADDRESS : _____

For Assistance, please call (773) 473-7080 to speak with one of our experts.

For fast, easy ordering, go to www.freeman.com/store

Qty	Part #	Description	Online Price	Discount Price	Standard Price	Total
Pedestal Tables (continued)						
_____	820912	30" Bar Table w/ Hydraulic Base - Green.....	304.00	334.40	425.60	_____
_____	820913	30" Bar Table w/ Hydraulic Base - Orange.....	304.00	334.40	425.60	_____
_____	820914	30" Bar Table w/ Hydraulic Base - Yellow.....	304.00	334.40	425.60	_____
_____	820915	30" Bar Table w/ Black Base - Gunmetal.....	212.80	234.10	297.90	_____
_____	820916	30" Bar Table w/ Black Base - Black.....	212.80	234.10	297.90	_____
_____	820917	30" Bar Table w/ Black Base - Green.....	212.80	234.10	297.90	_____
_____	820918	30" Bar Table w/ Black Base - Orange.....	212.80	234.10	297.90	_____
_____	820919	30" Bar Table w/ Black Base - Yellow.....	212.80	234.10	297.90	_____
_____	8201230	30" Cafe Table w/ Hydraulic Base - Gunmetal.....	304.00	334.40	425.60	_____
_____	8201231	30" Cafe Table w/ Hydraulic Base - Black.....	304.00	334.40	425.60	_____
_____	8201232	30" Cafe Table w/ Hydraulic Base - Green.....	304.00	334.40	425.60	_____
_____	8201233	30" Cafe Table w/ Hydraulic Base - Orange.....	304.00	334.40	425.60	_____
_____	8201234	30" Cafe Table w/ Hydraulic Base - Yellow.....	304.00	334.40	425.60	_____
_____	8201235	30" Cafe Table w/ Black Base - Gunmetal.....	197.60	217.35	276.65	_____
_____	8201236	30" Cafe Table w/ Black Base - Black.....	197.60	217.35	276.65	_____
_____	8201237	30" Cafe Table w/ Back Base - Green.....	197.60	217.35	276.65	_____
_____	8201238	30" Cafe Table w/ Black Base - Orange.....	197.60	217.35	276.65	_____
_____	8201239	30" Cafe Table w/ Black Base - Yellow.....	197.60	217.35	276.65	_____
_____	8201240	36" Bar Table w/ Hydraulic Base - Black.....	313.50	344.85	438.90	_____
_____	8201241	36" Bar Table w// Black Base - Black.....	214.70	236.15	300.60	_____
_____	8201242	36" Cafe Table w/ Hydraulic Base - Black.....	300.20	330.20	420.30	_____
_____	8201243	36" Cafe Table w// Black Base - Black.....	231.80	255.00	324.50	_____
Accent Tables						
_____	82015	Silverado End Table - Tempered Glass/Painted Steel.....	195.70	215.25	274.00	_____
_____	82014	Silverado Cocktail Table - Tempered Glass/Painted Steel.....	209.00	229.90	292.60	_____
_____	820252	Alondra End Table - Glass/Chrome.....	171.00	188.10	239.40	_____
_____	820250	Alondra Cocktail Table - Glass/Chrome.....	239.40	263.35	335.15	_____
_____	820253	Alondra End Table - Wood/Chrome.....	171.00	188.10	239.40	_____
_____	820251	Alondra Cocktail Table - Wood/Chrome.....	239.40	263.35	335.15	_____
_____	8201224	Atomic 36" Round Table - Glass/Chrome.....	266.00	292.60	372.40	_____
_____	8201225	Atomic 42" Round Table - Glass/Chrome.....	266.00	292.60	372.40	_____
_____	82028	Geo End Table - Wood/Black Steel.....	203.30	223.65	284.60	_____
_____	82027	Geo Cocktail Table - Wood/Black Steel.....	207.10	227.80	289.95	_____
_____	82035	Geo End Table - Glass/Chrome.....	150.10	165.10	210.15	_____
_____	82034	Geo Cocktail Table - Glass/Chrome.....	140.60	154.65	196.85	_____
_____	82054	Sydney End Table - Black Laminate/Brushed Steel..	182.40	200.65	255.35	_____
_____	82055	Sydney End Table - White Laminate/Brushed Steel..	182.40	200.65	255.35	_____
_____	82052	Sydney Cocktail Table - Black Laminate/Brushed Steel.....	220.40	242.45	308.55	_____
_____	82053	Sydney Cocktail Table - White Laminate/Brushed Steel.....	220.40	242.45	308.55	_____
_____	82079	Sydney End Table - Blue Laminate/Brushed Steel....	178.60	196.45	250.05	_____
_____	82080	Sydney End Table - Wood Laminate/Brushed Steel..	178.60	196.45	250.05	_____
_____	82077	Sydney Cocktail Table - Blue Laminate/Brushed Steel.....	216.60	238.25	303.25	_____
_____	82078	Sydney Cocktail Table - Wood Laminate/Brushed Steel.....	216.60	238.25	303.25	_____
_____	82075	Regis End Table - Brushed Metal.....	180.50	198.55	252.70	_____

NAME OF SHOW: **NECANN - ILLINOIS CANNABIS CONVENTION / APRIL 3 - 4, 2020**

COMPANY NAME: _____ BOOTH #: _____ BOOTH SIZE: X

CONTACT NAME : _____ PHONE #: _____

E-MAIL ADDRESS : _____

For Assistance, please call (773) 473-7080 to speak with one of our experts.

For fast, easy ordering, go to www.freeman.com/store

Qty	Part #	Description	Online Price	Discount Price	Standard Price	Total
Accent Tables (continued)						
	82074	Regis Bench Table - Brushed Metal.....	254.60	280.05	356.45	
	820844	Aura Round Table - White Metal.....	98.80	108.70	138.30	
	82057	Edge LED Cube Table-White Plastic/Clear Acrylic.....	152.00	167.20	212.80	
	82043	Geo Square-Round Table - Glass/Black Steel.....	241.30	265.45	337.80	
	82044	Geo Square-Round Table - Glass/Chrome.....	241.30	265.45	337.80	
	8201226	Rustique Square Metal Bar Table - Gray.....	233.70	257.05	327.20	
	820130	Mesa Cocktail Table - Black/Bronze.....	219.45	241.40	307.25	
	820131	Mesa Cocktail Table - Glass/Bronze.....	219.45	241.40	307.25	
	820132	Mesa Cocktail Table - Wood/Bronze.....	219.45	241.40	307.25	
	820133	Mesa End Table - Black/Bronze.....	194.40	213.85	272.15	
	820134	Mesa End Table - Glass/Bronze.....	194.40	213.85	272.15	
	820135	Mesa End Table - Wood/Bronze.....	194.40	213.85	272.15	
	820310	Sedona Side Table - Black/Bronze.....	105.00	115.50	147.00	
	820311	Sedona Side Table - Wood/Bronze.....	105.00	115.50	147.00	
	820312	Sedona Side Table - White/Bronze.....	105.00	115.50	147.00	
	820320	Taos Side Table - Black/Bronze.....	105.00	115.50	147.00	
	820321	Taos Side Table Wood/Bronze.....	105.00	115.50	147.00	
	820322	Taos Side Table - White/Bronze.....	105.00	115.50	147.00	
Conference Tables						
	82041	Geo Conference Table - Glass/Black Steel.....	300.20	330.20	420.30	
	82051	Geo Conference Table - Glass/Chrome.....	296.40	326.05	414.95	
	820260	Madison Conference Table - Gray Acajou.....	317.30	349.05	444.20	
	820708	42" Round Conference Table - White Laminate.....	313.50	344.85	438.90	
	820203	6' Oval Conference Table - Graphite.....	427.50	470.25	598.50	
	820261	Madison 5' Conference Table - Gray Acajou.....	385.70	424.25	540.00	
	820262	Madison 8' Conference Table - Gray Acajou.....	767.60	844.35	1,074.65	
	820263	Madison 10' Conference Table - Gray Acajou.....	767.60	844.35	1,074.65	
	820951	Ventura Bar Table - Maple w/ Grommets.....	575.70	633.25	806.00	
	820952	Ventura Communal Bar Table - Black.....	564.30	620.75	790.00	
	820953	Ventura Bar Table - White w/ Grommets.....	575.70	633.25	806.00	
	820954	Ventura Communal Bar Table - Maple.....	575.70	633.25	806.00	
	820956	Ventura Communal Bar Table - White.....	575.70	633.25	806.00	
	820963	Ventura Communal Cafe Table - Maple.....	376.20	413.80	526.70	
	820960	Ventura Cafe Table - Maple w/ Grommets.....	564.30	620.75	790.00	
	820961	Ventura Cafe Table - White w/ Grommets.....	564.30	620.75	790.00	
	820966	Ventura Communal Cafe Table - White.....	376.20	413.80	526.70	
	820962	Ventura Communal Cafe Table - Black.....	376.20	413.80	526.70	
	8201244	42" Round Conference Table - Black Laminate.....	313.50	344.85	438.90	
Office						
	84075	Madison Desk - Gray Acajou.....	452.20	497.40	633.10	
	84077	Madison Credenza - Gray Acajou.....	378.10	415.90	529.35	
	84078	Madison Bookcase - Gray Acajou.....	323.00	355.30	452.20	
Computer Desks/Tables						
	820706	Work Desk - White Laminate.....	269.80	296.80	377.70	
	820707	Merlin Table - Gray Laminate.....	279.30	307.25	391.00	

FREEMAN furnishings

Take advantage of the Online price
by ordering at www.freeman.com before
MARCH 12, 2020

NAME OF SHOW: **NECANN - ILLINOIS CANNABIS CONVENTION / APRIL 3 - 4, 2020**

COMPANY NAME: _____ BOOTH #: _____ BOOTH SIZE: X

CONTACT NAME : _____ PHONE #: _____

E-MAIL ADDRESS : _____

For Assistance, please call (773) 473-7080 to speak with one of our experts.

For fast, easy ordering, go to www.freeman.com/store

Qty	Part #	Description	Online Price	Discount Price	Standard Price	Total
-----	--------	-------------	--------------	----------------	----------------	-------

POWERED

Powered Seating

_____	810120	Naples Chair, Powered - Black Vinyl.....	532.00	585.20	744.80	_____
_____	830122	Naples Loveseat, Powered - Black Vinyl.....	716.30	787.95	1,002.80	_____
_____	830121	Naples Sofa, Powered - Black Vinyl.....	822.70	904.95	1,151.80	_____
_____	81021	Roma Chair, Powered - White Vinyl.....	532.00	585.20	744.80	_____
_____	83017	Roma Sofa, Powered - White Vinyl.....	822.70	904.95	1,151.80	_____

Powered Tables

_____	820950	Ventura Communal Bar Table, Powered - Black.....	697.30	767.05	976.20	_____
_____	820955	Ventura Communal Bar Table, Powered - White.....	634.60	698.05	888.45	_____
_____	820964	Ventura Communal Cafe Table, Powered - Black.....	476.90	524.60	667.65	_____
_____	820965	Ventura Communal Cafe Table, Powered - White.....	476.90	524.60	667.65	_____
_____	84083	Tech Desk w/ 3 Drawer File Cabinet, Powered - Black Metal.....	467.40	514.15	654.35	_____
_____	84084	Tech Desk, Powered - Black Metal.....	410.40	451.45	574.55	_____
_____	82076	Sydney Cocktail Table, Powered - Black.....	317.30	349.05	444.20	_____
_____	82073	Sydney Cocktail Table, Powered - White.....	317.30	349.05	444.20	_____

Powered Pedestals

_____	85060	Powered Locking Pedestal 36" H, Black.....	387.60	426.35	542.65	_____
_____	85061	Powered Locking Pedestal 36" H, White.....	387.60	426.35	542.65	_____
_____	85062	Powered Locking Pedestal 42" H, Black.....	463.60	509.95	649.05	_____
_____	85063	Powered Locking Pedestal 42" H, White.....	463.60	509.95	649.05	_____
_____	820710	Wireless Charging Table, Powered.....	378.10	415.90	529.35	_____

Midtown Counters & Bars

_____	850103	Midtown Powered Counter Unlighted - Pewter.....	1,138.10	1,251.90	1,593.35	_____
_____	850102	Midtown Powered Counter Lighted w/ Plug-In - Pewter.....	1,328.10	1,460.90	1,859.35	_____
_____	850101	Midtown Bar Unlighted - Pewter.....	1,024.10	1,126.50	1,433.75	_____
_____	850100*	Midtown Bar Lighted w/ Plug-In - Pewter.....	1,214.10	1,335.50	1,699.75	_____

DISPLAY & ACCESSORIES

Product Storage

_____	84080	3 Door File Cabinet on Castors - Black	142.50	156.75	199.50	_____
_____	74082	File Cabinet w/Lock - Two Drawer - Standard Size...	218.10	239.90	305.35	_____
_____	74081	File Cabinet w/Lock - Four Drawer - Standard Size..	340.40	374.45	476.55	_____
_____	85020	Posh Shelving w/ Chrome Frame - White.....	423.70	466.05	593.20	_____

Refrigerator

_____	75057	Small Refrigerator.....	418.00	459.80	585.20	_____
_____	8503001	Refrigerator - White.....	592.80	652.10	829.90	_____

Lighting

_____	850707	Mason Table Lamp - White/Brushed Silver.....	117.80	129.60	164.90	_____
_____	850708*	Mason Floor Lamp - White/Brushed Silver.....	176.70	194.35	247.40	_____

Display

_____	75020	Display Cylinder - Black - Low.....	368.10	404.90	515.35	_____
_____	75021	Display Cylinder - Black - Medium.....	368.10	404.90	515.35	_____
_____	75022	Display Cylinder - Black - High.....	368.10	404.90	515.35	_____
_____	75030	Display Cube - Black - 12" Small.....	362.95	399.25	508.15	_____

FREEMAN furnishings

Take advantage of the Online price by ordering at www.freeman.com before MARCH 12, 2020

NAME OF SHOW: **NECANN - ILLINOIS CANNABIS CONVENTION / APRIL 3 - 4, 2020**

COMPANY NAME: _____ BOOTH #: _____ BOOTH SIZE: **X**

CONTACT NAME : _____ PHONE #: _____

E-MAIL ADDRESS : _____

For Assistance, please call (773) 473-7080 to speak with one of our experts.

For fast, easy ordering, go to www.freeman.com/store

Qty	Part #	Description	Online Price	Discount Price	Standard Price	Total
Display (continued)						
_____	75031	Display Cube - Black - 18" Medium.....	388.60	427.45	544.05	_____
_____	75032	Display Cube - Black - 24" Large.....	440.15	484.15	616.20	_____
_____	75079	Orion Computer Kiosk - Black.....	714.35	785.80	1,000.10	_____
_____	72056	Display Counter - Black.....	358.25	394.10	501.55	_____
Boxwood Hedges						
_____	85030	7' Boxwood Hedge.....	539.60	593.55	755.45	_____
_____	85035	4' Boxwood Hedge.....	288.80	317.70	404.30	_____
Accessories						
_____	220121	Chrome Stanchion w/ 8' Retractable Belt.....	125.90	138.50	176.25	_____
_____	220118	Chrome Sign Holder.....	160.45	176.50	224.65	_____
_____	750135	Round Literature Rack.....	336.95	370.65	471.75	_____
_____	750136	Flat Literature Rack.....	298.00	327.80	417.20	_____
_____	220109	Chrome Coat Tree.....	59.75	65.75	83.65	_____
_____	220134	Aluminum Easel.....	64.80	71.30	90.70	_____
_____	220110	Chrome Bag Rack.....	160.45	176.50	224.65	_____
_____	10201484	Floor Standing Bulletin Board.....	350.15	385.15	490.20	_____
_____	220106	Corrugated Wastebasket.....	18.90	20.80	26.45	_____
Special Drape						
<input type="checkbox"/> Black <input type="checkbox"/> Blue <input type="checkbox"/> Brown <input type="checkbox"/> Green <input type="checkbox"/> Flax <input type="checkbox"/> Gold <input type="checkbox"/> Gray <input type="checkbox"/> Plum <input type="checkbox"/> Red <input type="checkbox"/> White						
_____	12103	Special Drape 3'H (per ft.).....	29.50	32.45	41.30	_____
_____	12108	Special Drape 8'H (per ft.).....	40.10	44.10	56.15	_____

TOTAL COST		
_____	+	_____ = _____
Sub-Total		9% Tax Total Cost

Taxes: Due to varying taxes across counties and cities for various categories, applicable taxes will be applied to your order accordingly based on the jurisdictions of the show city.

FREEMAN furnishings

Take advantage of the Online price
by ordering at www.freeman.com before
MARCH 12, 2020

NAME OF SHOW: **NECANN - ILLINOIS CANNABIS CONVENTION / APRIL 3 - 4, 2020**

COMPANY NAME: _____ BOOTH #: _____ BOOTH SIZE: **X**



CONTACT NAME : _____ PHONE #: _____

E-MAIL ADDRESS : _____

For Assistance, please call **(773) 473-7080** to speak with one of our experts.

For fast, easy ordering, go to www.freeman.com/store

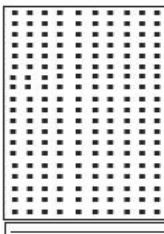
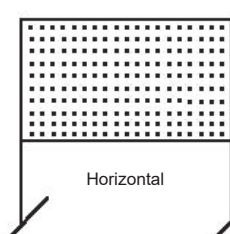
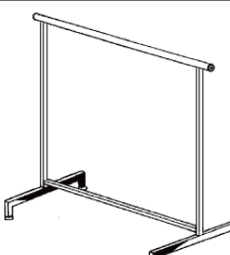
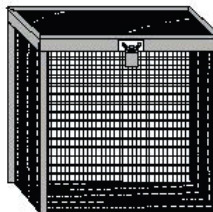
ACCESSORIES

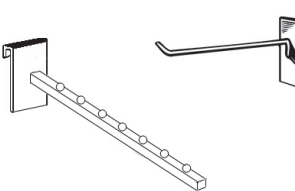
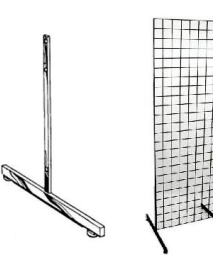
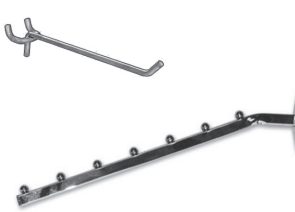
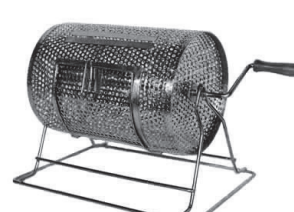
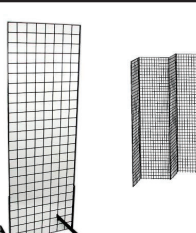
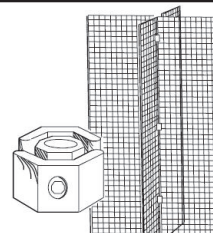
 <p>Vertical</p> <p>PERFBOARD SINGLE SIDED</p>	 <p>Horizontal</p> <p>PERFBOARD SINGLE SIDED</p>	 <p>CHROME GARMENT RACK</p>	 <p>COLLAPSIBLE SECURITY CONTAINER</p>
 <p>2 WAY STRAIGHT ARM</p>	 <p>4 WAY SLANT ARM</p>	 <p>GRID ACCESSORIES</p>	 <p>GRID LEGS</p>
 <p>PERFBOARD HOOKS AND ACCESSORIES</p>	 <p>TICKET TUMBLER</p>	 <p>2' x 8' GRID PANELS</p>	 <p>4 WAY CONNECTORS</p>

Qty	Part #	Description	Online Price	Discount Price	Standard Price	Total
PERFBOARDS / BULLETIN BOARDS						
___	10201178	1M x 8'H Single Side-Vert (White)...	344.30	378.75	482.00	_____
___	10201179	1M x 8'H Single Side-Vert (Gray)...	N/A	N/A	N/A	_____
___	10201182	1/2 M x 8'H Single Side-Vert.....	259.25	285.20	362.95	_____
___	10201480	4' x 8' Single Side-Horz.....	344.30	378.75	482.00	_____
___	102040	4" Single Hook.....	4.60	5.05	6.45	_____
___	102060	6" Single Hook.....	4.60	5.05	6.45	_____
___	102080	8" Single Hook.....	4.60	5.05	6.45	_____
___	10205	12" Shelf Bracket.....	28.65	31.50	40.10	_____
___	10207	7-Ball Waterfall Arm.....	53.25	58.60	74.55	_____

Qty	Part #	Description	Online Price	Discount Price	Standard Price	Total
GRIDS						
___	103028	Chrome Grid.....	154.75	170.25	216.65	_____
___	103010	Black Grid.....	154.75	170.25	216.65	_____
___	103011	White Grid.....	N/A	N/A	N/A	_____
___	103040	Grid Legs (Chrome).....	59.45	65.40	83.25	_____
___	103041	Grid Legs (Black).....	59.45	65.40	83.25	_____
___	103042	Grid Legs (White).....	N/A	N/A	N/A	_____
___	103030	Grid Connectors.....	19.45	21.40	27.25	_____

Qty	Part #	Description	Online Price	Discount Price	Standard Price	Total
GRIDS (continued)						
___	10303	3-Ball Waterfall Arm.....	44.75	49.25	62.65	_____
___	10305	5-Ball Waterfall Arm.....	47.75	52.55	66.85	_____
___	10307	7-Ball Waterfall Arm.....	53.25	58.60	74.55	_____
___	10309	Cleaver Clip.....	N/A	N/A	N/A	_____
___	103044	4" Single Hook.....	4.60	5.05	6.45	_____
___	103046	6" Single Hook.....	4.60	5.05	6.45	_____
___	103048	8" Single Hook.....	4.60	5.05	6.45	_____

Qty	Part #	Description	Online Price	Discount Price	Standard Price	Total
ACCESSORIES						
___	151010	Collapsible Security Container.....	N/A	N/A	N/A	_____
___	15905	Fish Bowl.....	50.30	55.35	70.40	_____
___	159011	Ticket Tumbler - Small.....	189.90	208.90	265.85	_____
___	10405	Garment Rack.....	207.00	227.70	289.80	_____
___	10404	4-way Slant Arm.....	259.25	285.20	362.95	_____
___	10403	2-way Straight Arm.....	206.15	226.75	288.60	_____

TOTAL COST		
_____	+	_____ = _____
Sub-Total	9 % Tax	Total Cost

Take advantage of the Online price by ordering at www.freeman.com before MARCH 12, 2020

FREEMAN

8201 West 47th St
 Mc Cook, IL 60525
 (773) 473-7080 Fax: (469) 621-5603
 FreemanChicagoES@freeman.com

**ONLINE PRICE
 DISCOUNT PRICE
 DEADLINE DATE
 MARCH 12, 2020**

NAME OF SHOW: **NECANN - ILLINOIS CANNABIS CONVENTION / APRIL 3 - 4, 2020**

COMPANY NAME: _____ BOOTH #: _____ BOOTH SIZE: _____ X

CONTACT NAME : _____ PHONE #: _____

E-MAIL ADDRESS : _____

For Assistance, please call (773) 473-7080 to speak with one of our experts.

- Orders received after the deadline or without payment will be charged the Standard price.
- All utility lines must be installed before carpet installation. Utilities should be ordered in advance.
- Pricing includes delivery, material handling, installation and removal.

All carpets, padding and plastic covering contain recycled content and are recyclable.

For fast, easy ordering, go to www.freeman.com/store

10' CLASSIC CARPET , PADDING & PLASTIC COVERING

CHOOSE YOUR CARPET COLOR:

- Black Blue Gray Green Latte Midnight Blue Plum Red Red Pepper Tuxedo

Qty	Description	Online Price	Discount Price	Standard Price	Total
_____	10' x 10' Classic Carpet	\$ 492.30	\$ 541.55	\$ 689.20	_____
_____	10' x 20' Classic Carpet	\$ 984.60	\$ 1,083.05	\$ 1,378.45	_____
_____	10' x 30' Classic Carpet	\$ 1,476.90	\$ 1,624.60	\$ 2,067.65	_____
_____	10' x 40' Classic Carpet	\$ 1,969.15	\$ 2,166.05	\$ 2,756.80	_____
_____	10' x 10' Carpet Padding - Single Layer.....	\$ 156.30	\$ 171.95	\$ 218.80	_____
_____	10' x 20' Carpet Padding - Single Layer.....	\$ 312.60	\$ 343.85	\$ 437.65	_____
_____	10' x 30' Carpet Padding - Single Layer.....	\$ 468.85	\$ 515.75	\$ 656.40	_____
_____	10' x 40' Carpet Padding - Single Layer.....	\$ 625.15	\$ 687.65	\$ 875.20	_____
_____	10' x 10' Carpet Padding - Double Layer.....	\$ 312.60	\$ 343.85	\$ 437.65	_____
_____	10' x 20' Carpet Padding - Double Layer.....	\$ 625.20	\$ 687.70	\$ 875.30	_____
_____	10' x 30' Carpet Padding - Double Layer.....	\$ 937.70	\$ 1,031.45	\$ 1,312.80	_____
_____	10' x 40' Carpet Padding - Double Layer.....	\$ 1,250.30	\$ 1,375.35	\$ 1,750.40	_____
_____	Plastic Covering (price per sq. ft.).....	\$.80	\$.90	\$ 1.10	_____

9' CLASSIC CARPET , PADDING & PLASTIC COVERING

CHOOSE YOUR CARPET COLOR:

- Black Blue Gray Green Latte Midnight Blue Plum Red Red Pepper Tuxedo

Qty	Description	Online Price	Discount Price	Standard Price	Total
_____	9' x 10' Classic Carpet	\$ 316.80	\$ 348.50	\$ 443.50	_____
_____	9' x 20' Classic Carpet	\$ 633.15	\$ 696.45	\$ 886.40	_____
_____	9' x 30' Classic Carpet	\$ 950.05	\$ 1,045.05	\$ 1,330.05	_____
_____	9' x 40' Classic Carpet	\$ 1,266.50	\$ 1,393.15	\$ 1,773.10	_____
_____	9' x 10' Carpet Padding - Single Layer.....	\$ 140.70	\$ 154.75	\$ 197.00	_____
_____	9' x 20' Carpet Padding - Single Layer.....	\$ 281.30	\$ 309.45	\$ 393.80	_____
_____	9' x 30' Carpet Padding - Single Layer.....	\$ 422.00	\$ 464.20	\$ 590.80	_____
_____	9' x 40' Carpet Padding - Single Layer.....	\$ 562.60	\$ 618.85	\$ 787.65	_____
_____	9' x 10' Carpet Padding - Double Layer.....	\$ 281.40	\$ 309.55	\$ 393.95	_____
_____	9' x 20' Carpet Padding - Double Layer.....	\$ 562.60	\$ 618.85	\$ 787.65	_____
_____	9' x 30' Carpet Padding - Double Layer.....	\$ 844.00	\$ 928.40	\$ 1,181.60	_____
_____	9' x 40' Carpet Padding - Double Layer.....	\$ 1,125.20	\$ 1,237.70	\$ 1,575.30	_____
_____	Plastic Covering (price per sq. ft.).....	\$.80	\$.90	\$ 1.10	_____

9' carpet is laid toward the front edge, leaving 1' at the back of the booth for access to utility ports.

TOTAL COST		
Sub- Total	+	9% Tax
	=	Total Cost

FREEMAN standard size carpet

Take advantage of the Online price by ordering at www.freeman.com before MARCH 12, 2020

FREEMAN

8201 West 47th St
 Mc Cook, IL 60525
 (773) 473-7080 Fax: (469) 621-5603
 FreemanChicagoES@freeman.com

**ONLINE PRICE
 DISCOUNT PRICE
 DEADLINE DATE
 MARCH 12, 2020**

NAME OF SHOW: **NECANN - ILLINOIS CANNABIS CONVENTION / APRIL 3 - 4, 2020**

COMPANY NAME: _____ BOOTH #: _____ BOOTH SIZE: _____ X

CONTACT NAME: _____ PHONE #: _____

E-MAIL ADDRESS: _____

For Assistance, please call (773) 473-7080 to speak with one of our experts.

- Guaranteed new, high-quality carpet.
- Orders received after the deadline or without payment will be charged the Standard price and are subject to availability.
- Prestige and Custom Cut Classic Carpet are subject to a 100% cancellation charge.
- All utility lines must be installed before carpet installation. Utilities should be ordered in advance.

All carpets, padding and plastic covering contain recycled content and are recyclable.

For fast, easy ordering, go to www.freeman.com/store

CUSTOM CUT CLASSIC CARPET - includes plastic covering, delivery, material handling, installation and removal

- Order Custom Cut Classic Carpeting by the sq. ft. if your size is not listed on the standard size order form.

Sample: Booth Size: 10 x 25 = 250 sq. ft. @ \$ **5.10**

CHOOSE YOUR CARPET COLOR - 16 oz. Carpet:

- Black Blue Gray Green Latte Midnight Blue Plum Red Red Pepper Tuxedo

16 oz. Carpet Rental - Price per sq. ft. (100 sq. ft. minimum)

Per sq. ft.	Booth Size: _____ x _____ = _____ sq. ft. @	Online Price	Discount Price	Standard Price	Total
		\$ 5.10	\$ 5.60	\$ 7.15	_____

PRESTIGE CARPET - includes plastic covering, delivery, material handling, installation and removal

CHOOSE YOUR CARPET COLOR - 28 oz. Carpet:

- Black Cardinal Charcoal Cream Gray Pearl Navy Toast Wedgewood White

28 oz. Carpet Rental - Price per sq. ft. (100 sq. ft. minimum)

	Booth Size: _____ x _____ = _____ sq. ft. @	Online Price	Discount Price	Standard Price	Total
1 - 700 sq. ft.		\$ 6.80	\$ 7.50	\$ 9.50	_____
Over 700 sq. ft.		\$ 5.80	\$ 6.40	\$ 8.10	_____

CHOOSE YOUR CARPET COLOR - 40 oz. Carpet:

- Black Charcoal Gray Pearl Navy White

40 oz. Carpet Rental - Price per sq. ft. (100 sq. ft. minimum)

	Booth Size: _____ x _____ = _____ sq. ft. @	Online Price	Discount Price	Standard Price	Total
1 - 700 sq. ft.		\$ 8.00	\$ 8.80	\$ 11.20	_____
Over 700 sq. ft.		\$ 7.20	\$ 7.90	\$ 10.10	_____

CARPET PADDING - includes delivery, material handling, installation and removal

- Order Carpet Padding by the sq. ft. if your size is not listed on the standard size order form.

Sample: Booth Size: 10 x 25 = 250 sq. ft. @ \$ **1.60**

Qty	Description	Price per sq. ft. (90 sq. ft. minimum)	Online Price	Discount Price	Standard Price	Total
_____	Carpet Padding -1/2" (90 - 700 sq. ft.)		\$ 1.60	\$ 1.75	\$ 2.25	_____
_____	Carpet Padding -1/2" (Over 700 sq. ft.)		\$ 1.40	\$ 1.55	\$ 1.95	_____
_____	Double Carpet Padding - 1/2" (90 - 700 sq. ft.)		\$ 3.20	\$ 3.50	\$ 4.50	_____
_____	Double Carpet Padding -1/2" (Over 700 sq. ft.)		\$ 2.80	\$ 3.10	\$ 3.90	_____

TOTAL COST

_____	+	_____	=	_____
Sub- Total		9% Tax		Total Cost

Take advantage of the Online price
 by ordering at www.freeman.com
 before MARCH 12, 2020

FREEMAN cut to size carpet

FREEMAN

8201 West 47th St
 Mc Cook, IL 60525
 (773) 473-7080 Fax: (469) 621-5603
 FreemanChicagoES@freeman.com

NAME OF SHOW: **NECANN - ILLINOIS CANNABIS CONVENTION / APRIL 3 - 4, 2020**

COMPANY NAME: _____ BOOTH #: _____ BOOTH SIZE: _____ X

CONTACT NAME : _____ PHONE #: _____

E-MAIL ADDRESS : _____

For Assistance, please call (773) 473-7080 to speak with one of our experts.

For fast, easy ordering, go to www.freeman.com/store

CLEANING SERVICES

- **Cleaning is an exclusive service. This includes all floor services and trash removal.**
- Prices are based on total square footage of booth regardless of area to be cleaned.
- **Show Site Prices will apply to all cleaning orders placed at show site.**

VACUUMING (per sq. ft. - 100 sq. ft. minimum)

Qty (sq. ft.)	Part #	Description	Advance Price	Show Site Price	Total
_____	610100	Booth Vacuuming - One Time80	1.10	_____
_____	610200	Booth Vacuuming - 2 Days	1.60	2.25	_____
_____	610300	Booth Vacuuming - 3 Days	N/A	N/A	_____
_____	610400	Booth Vacuuming - 4 Days	N/A	N/A	_____

• Includes emptying of your booth's wastebasket(s) at the time of vacuuming.

SHAMPOOING (per sq ft - 100 sq ft minimum)

Qty (sq. ft.)	Part #	Description	Advance Price	Show Site Price	Total
_____	630100	Shampoo Carpet - One Time	1.45	2.05	_____
_____	630200	Shampoo Carpet - 2 Days	2.90	4.05	_____
_____	630300	Shampoo Carpet - 3 Days	N/A	N/A	_____

PORTER SERVICE (per day)

Qty (# days)	Part #	Description	Advance Price	Show Site Price	Total
_____	620500	Exhibit Area / Under 500 sq.ft.	101.05	141.45	_____
_____	6201500	Exhibit Area / 501 - 1,500 sq. ft.	144.85	202.80	_____
_____	6202500	Exhibit Area / 1,501 - 2,500 sq. ft.	173.75	243.25	_____
_____	6203500	Exhibit Area / Over 2,500 sq.ft.....			Call for Quote

TOTAL COST

_____	+	_____	=	_____
Sub-Total		N/A %Tax		Total Cost

FREEMAN

8201 West 47th St
 Mc Cook, IL 60525
 (773) 473-7080 Fax: (469) 621-5603
 FreemanChicagoES@freeman.com

**DISCOUNT PRICE
 DEADLINE DATE
 MARCH 12, 2020**

NAME OF SHOW: **NECANN - ILLINOIS CANNABIS CONVENTION / APRIL 3 - 4, 2020**

COMPANY NAME: _____ BOOTH #: _____ BOOTH SIZE: X

CONTACT NAME : _____ PHONE #: _____

E-MAIL ADDRESS : _____

For Assistance, please call (773) 473-7080 to speak with one of our experts.

For fast, easy ordering, go to www.freeman.com/store

SMARTFABRIC EXHIBIT

SmartFabric Exhibits provide a custom printed fabric graphic to keep and reuse on future events.



SmartFabric Rental Exhibit Includes:

- 116.5" X 92.5" Custom Fabric Graphic (Purchased item to keep)
- Carrying Case for Graphic (To carry the purchased fabric graphic)
- Classic Carpet 9' X 10' or 9' X 20' (Select color below)
- Installation & Dismantle of Exhibit
- Material Handling of Exhibit
- Nightly Vacuuming
- 3-Arm Lights (per 10 ft.)
- Power for LIGHTS only

Classic Carpet: Black Blue Gray Green Latte
 Midnight Blue Plum Red Red Pepper Tuxedo

Qty	Description	Discount	Standard	Total
_____	10' x 10' SmartFabric Exhibit.....	\$ 2,801.50	\$ 3,922.10	_____
_____	10' x 20' SmartFabric Exhibit.....	\$ 5,401.50	\$ 7,562.10	_____

CUSTOM GRAPHICS

A Freeman Exhibitor Sales Specialist will be contacting you to review the process for providing graphic files and helpful tips that will ensure a successful graphic print.

FRAME ONLY UNIT

The SmartFabric frame only unit is for exhibitors who have previously rented the SmartFabric exhibit (above) and have the fabric graphic ready for reuse. If you need a new graphic made, please select the SmartFabric Rental Exhibit (above). No fabric graphics will be printed without the rental unit.



Frame Only Unit Includes:

- Classic Carpet 9' X 10' or 9' X 20' (Select color below)
- Installation & Dismantle of Exhibit
- Material Handling of Exhibit
- Nightly Vacuuming
- 3-Arm Lights (per 10 ft.)
- Power for LIGHTS only
- Where is your fabric coming from?:
 Bringing to show site
 In Freeman storage

Classic Carpet: Black Blue Gray Green Latte
 Midnight Blue Plum Red Red Pepper Tuxedo

Qty	Description	Discount	Standard	Total
_____	10' x 10' Frame Only Unit.....	\$ 1,833.00	\$ 2,566.20	_____
_____	10' x 20' Frame Only Unit.....	\$ 3,055.00	\$ 4,277.00	_____

ACCESSORIES

Qty	Description	Discount	Standard	Total
_____	SmartFabric Arm Light	\$ 65.00	\$ 91.00	_____
_____	SmartFabric Acrylic Shelf (supports up to 15 lbs).....	\$ 150.00	\$ 210.00	_____
_____	SmartFabric Carrying Case (purchase).....	\$ 20.00	\$ 28.00	_____

QUICK TIPS

• Orders received after the deadline or without payment will be charged the Standard price and are subject to availability. All graphics are subject to a 100% cancellation charge once production begins.

☺ The product offered has recyclable content or has eco-friendly attributes and is 100% recyclable according to manufacturer's specifications.

9' carpet is laid toward the front edge, leaving 1' at the back of the booth for access to utility ports.

TOTAL COST		
_____	+	_____ = _____
Sub-Total		9 % Tax Total Cost

FREEMAN

8201 West 47th St
 Mc Cook, IL 60525
 (773) 473-7080 Fax: (469) 621-5603
 FreemanChicagoES@freeman.com

**DISCOUNT PRICE
 DEADLINE DATE
 MARCH 12, 2020**

rental exhibits
 FREEMAN

NAME OF SHOW: **NECANN - ILLINOIS CANNABIS CONVENTION / APRIL 3 - 4, 2020**

COMPANY NAME: _____ BOOTH #: _____ BOOTH SIZE: _____ X

CONTACT NAME : _____ PHONE #: _____

E-MAIL ADDRESS : _____

For Assistance, please call (773) 473-7080 to speak with one of our experts.

[For fast, easy ordering, go to www.freeman.com/store](http://www.freeman.com/store)

All Exhibits Include: installation & dismantle of exhibit, material handling of exhibit, 9' x 10' or 9' x 20' classic carpet with nightly vacuuming, 2 arm lights (per 10' unit), power (500 watts) for lights ONLY and labor to hang arm lights.

To place your order, please check the appropriate box and complete the remaining selections at the bottom of the form.

RENTAL EXHIBITS

		Discount Price	Standard Price		Discount Price	Standard Price	
Package 1	<input type="checkbox"/> 10' x 10'	4,284.65	5,998.50	<input type="checkbox"/> 10' x 20'	8,391.10	11,747.55	_____
Package 2	<input type="checkbox"/> 10' x 10'	2,550.35	3,570.50	<input type="checkbox"/> 10' x 20'	4,922.25	6,891.15	_____
Package 3	<input type="checkbox"/> 10' x 10'	3,621.05	5,069.45	<input type="checkbox"/> 10' x 20'	7,063.70	9,889.20	_____
Package 4	<input type="checkbox"/> 10' x 10'	3,630.70	5,083.00	<input type="checkbox"/> 10' x 20'	7,065.55	9,891.75	_____
Package 5	<input type="checkbox"/> 10' x 10'	3,814.05	5,339.65	<input type="checkbox"/> 10' x 20'	7,476.45	10,467.05	_____
Package 6	<input type="checkbox"/> 10' x 10'	3,976.00	5,566.40	<input type="checkbox"/> 10' x 20'	7,860.50	11,004.70	_____

CHOOSE YOUR PANEL

- Black Fabric
 Blue Fabric
 Gray Fabric
 White Hardwall
 White Perfboard

CARPET

Our Classic Carpet and nightly vacuuming are included in the price of your Rental Exhibit. The following colors are available:

Check color choice

- Black Blue Gray Green Latte
 Midnight Blue Plum Red Red Pepper Tuxedo

You may want to add padding or upgrade your carpet to one of our 15 designer colors in our PRESTIGE carpet line. Now available in **28 oz.** and **40 oz.** weight. Refer to our enclosed Carpet order form for color selections and pricing.

LIGHTING

Each Rental Exhibit includes 2 Arm Lights (per 10' unit).

Note: Power and labor to hang the lights are included in our standard rental exhibit package price. Power consumption not to exceed 500 Watts.

Additional power must be ordered separately.

HEADER IDENTIFICATION SIGN

Indicate which color lettering you would like. We have a wide variety of standard colors available:

- Black Blue Brown Burgundy PMS Color _____
 Red Teal White Green Font Type _____

Indicate exactly how you want your company name to appear:

*Unless font type is indicated, Helvetica will be used.

ENHANCE YOUR EXHIBIT

Enhance your exhibit and have an Exhibitor Sales Specialist contact you for pricing by checking any of the following boxes:

- Slatwall & Shelves Cabinets & Counters Specialty Colored Metal Recyclable Graphics
 Colored Panels Creating a Custom Exhibit Graphics & Custom Logo White Eco-Board

The product offered has recyclable content or has eco-friendly attributes and is 100% recyclable according to manufacturer's specifications.

TOTAL COST		
_____	+	_____ = _____
Sub-Total		9 % Tax Total Cost

FREEMAN

8201 West 47th St
 Mc Cook, IL 60525
 (773) 473-7080 Fax: (469) 621-5603
 FreemanChicagoES@freeman.com

**DISCOUNT PRICE
 DEADLINE DATE
 MARCH 12, 2020**

NAME OF SHOW: **NECANN - ILLINOIS CANNABIS CONVENTION / APRIL 3 - 4, 2020**



COMPANY NAME: _____ BOOTH #: _____ BOOTH SIZE: _____ X

CONTACT NAME: _____ PHONE #: _____

E-MAIL ADDRESS: _____

For Assistance, please call (773) 473-7080 to speak with one of our experts.

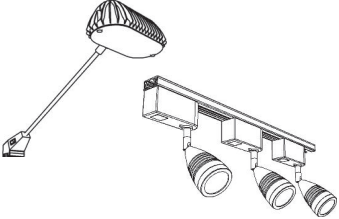
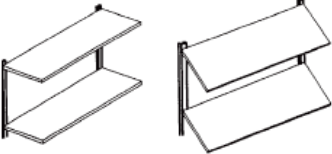
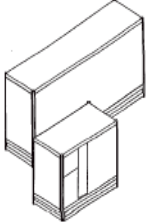
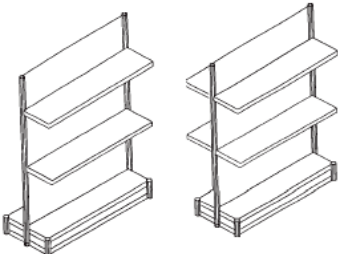
**For fast, easy ordering, go to www.freeman.com/store
 ACCESSORIES FOR RENTAL UNITS**

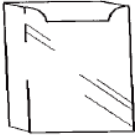
LIGHTS (use only on rentals) 	SHELVES (use only on rentals) 	CABINETS 
GONDOLAS 	RADIUS CABINET (does not have doors) 	LITERATURE POCKETS 

Qty	Part #	Description	Discount Price	Standard Price	Total
LIGHT FIXTURES					
(electrical service & labor to install lights not included)					
___	172512	Arm Light	162.65	227.70	_____
___	172514	4' Tracklight (3 lights)	494.50	692.30	_____
___	17252	Halogen Light	N/A	N/A	_____

CABINETS & LOCKS					
Cabinets					
<input type="checkbox"/> Black Fabric <input type="checkbox"/> Blue Fabric <input type="checkbox"/> Gray Fabric <input type="checkbox"/> White PVC					
___	17305	1M x 1/2M x 36" High.....	853.55	1,194.95	_____
___	17306	1M x 1/2M x 42" High.....	955.80	1,338.10	_____
___	17308	2M x 1/2M x 36" High.....	1,074.95	1,504.95	_____
___	17309	2M x 1/2M x 42" High.....	1,125.55	1,575.75	_____
___	173010	1M Radius x 1/2M x 36" High.	799.25	1,118.95	_____
___	173011	1M Radius x 1/2M x 42" High..	934.95	1,308.95	_____
(Radius Cabinets do not have doors)					
___	17301	Cabinet Lock	34.65	48.50	_____
Inside Shelves Available Quoted on Request					

Qty	Part #	Description	Discount Price	Standard Price	Total
GONDOLAS					
Gondolas					
<input type="checkbox"/> Blue Fabric <input type="checkbox"/> Gray Fabric <input type="checkbox"/> Perboard <input type="checkbox"/> White PVC					
___	174541	Single Sided 1M x 4' High...	579.85	811.80	_____
___	174542	Double Sided 1M x 4' High..	724.75	1,014.65	_____
___	174581	Single Sided 1M x 8' High...	802.70	1,123.80	_____
___	174582	Double Sided 1M x 8' High..	1,003.60	1,405.05	_____

SHELVES					
___	17201	1M Straight (37" x 12")	148.25	207.55	_____
___	17206	1M Angled (37" x 12")	148.25	207.55	_____

LITERATURE POCKETS					
___	174015	For 8 1/2 x 11 Literature	51.35	71.90	_____

TOTAL COST					
_____	+	_____	=	_____	_____
Sub-Total		9% Tax		Total Cost	

Don't see what you need?
 Please call Exhibitor Sales at (773) 473-7080.

** Remember to make a selection for items with checkboxes. Otherwise, a selection will be made for you.*

FREEMAN

8201 West 47th St
 Mc Cook, IL 60525
 (773) 473-7080 Fax: (469) 621-5603
 FreemanChicagoES@freeman.com

**DISCOUNT PRICE
 DEADLINE DATE
 MARCH 12, 2020**

FREEMAN totalflex

NAME OF SHOW: **NECANN - ILLINOIS CANNABIS CONVENTION / APRIL 3 - 4, 2020**

COMPANY NAME: _____ BOOTH #: _____ BOOTH SIZE: _____ X

CONTACT NAME : _____ PHONE #: _____

E-MAIL ADDRESS : _____

For Assistance, please call (773) 473-7080 to speak with one of our experts.

For fast, easy ordering, go to www.freeman.com/store

TABLETOP UNIT

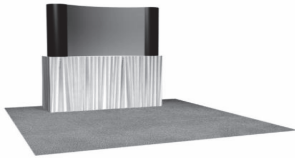

RENTAL			QTY	TOTAL
Size	Discount Price	Standard Price		
40"H x 6'W	1,578.60	2,210.05	_____	_____
40"H x 8'W	1,841.55	2,578.15	_____	_____
PURCHASE*				
Size	Discount Price	Standard Price		
40"H x 6'W	1,974.90	2,764.85	_____	_____
40"H x 8'W	2,236.25	3,130.75	_____	_____

*Shipping Not Included

Rental Units Include:
 Draped Table (select color below)
 Classic Carpet 9' X 10' (select color below)
 Installation & Dismantle of Exhibit
 Material Handling of Exhibit
 Nightly Vacuuming
 1-200 Watt Halogen Light (Power (500 watts) for LIGHTS only and Labor to hang lights)

Purchase Units Include:
 1-Case
 One Time Installation & Dismantle

Header Identification Sign - (white with black text) Indicate copy below:

Fabric Panel Colors for All Units: Black Gray Blue

**Other Colors Also Available for Purchase Units*

9' x 10' Classic Carpet: Black Blue Green Gray
 Latte Midnight Blue Plum Red Red Pepper Tuxedo

Table Drape:

Black Blue Brown Green Flax
 Gold Gray Plum Red White

FLOOR UNIT

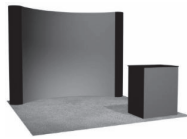

RENTAL			QTY	TOTAL
Size	Discount Price	Standard Price		
8'H x 8'W	2,634.35	3,688.10	_____	_____
8'H x 10'W	3,150.00	4,410.00	_____	_____
PURCHASE*				
Size	Discount Price	Standard Price		
8'H x 8'W	4,477.60	6,268.65	_____	_____
8'H x 10'W	5,256.40	7,358.95	_____	_____

*Shipping Not Included

Rental Units Include:
 Classic Carpet 9' X 10' (select color below)
 Installation & Dismantle of Exhibit
 Material Handling of Exhibit
 Nightly Vacuuming
 1-Podium - 8'H X 10'W unit only
 2-200 Watt Halogen Lights (Power (500 watts) for LIGHTS only and Labor to hang lights)

Purchase Units Include:
 2-Cases
 One Time Installation & Dismantle
 1-Podium - 8'H X 10'W unit only

Header Identification Sign - (white with black text) Indicate copy below:

Fabric Panel Colors for All Units: Black Gray Blue

**Other Colors Also Available for Purchase Units*

9' x 10' Classic Carpet: Black Blue Green Gray
 Latte Midnight Blue Plum Red Red Pepper Tuxedo

• All Classic carpet contain recycled content and are recyclable.

CUSTOM GRAPHIC / PHOTO PANELS

Our custom graphic panels can dramatically enhance your exhibit's appearance.

Please check the box to have an Exhibitor Sales Specialist contact you to assist in creating a unique exhibit.

OPTIONAL ACCESSORIES			RENTAL			PURCHASE			
Part #	Description	Qty	Discount Price	Standard Price	Total	Qty	Discount Price	Standard Price	Total
1715800	2-200 Watt Halogen Light Kit	_____	272.10	380.95	_____	_____	387.00	541.80	_____
1715801	1-200 Watt Halogen Light Kit	_____	143.25	200.55	_____	_____	281.75	394.45	_____
1715802	Straight Shelf	_____	109.75	153.65	_____	_____	215.70	302.00	_____
1715803	Angled Shelf	_____	109.75	153.65	_____	_____	215.70	302.00	_____

QUICK TIPS

* If shipping literature or products, material handling rates will apply.

* Order in advance to save time, money and ensure availability. **Orders received after the deadline date or without payment will be charged the Standard Price.**

PURCHASE UNITS TOTAL COST

Sub-Total + 10.25% Tax = Total Cost

RENTAL UNITS TOTAL COST

Sub-Total + 9% Tax = Total Cost

FREEMAN

8201 West 47th Street
 McCook, IL 60525
 Ph: (773) 473-7080 • Fax: (469) 621-5603
 FreemanChicagoES@freeman.com

ONLINE PRICE
DISCOUNT PRICE
DEADLINE DATE
MARCH 12, 2020

FREEMAN showcases

NAME OF SHOW: **NECANN - ILLINOIS CANNABIS CONVENTION / APRIL 3 - 4, 2020**

COMPANY NAME: _____ BOOTH #: _____

CONTACT NAME: _____ PHONE #: _____

E-MAIL ADDRESS: _____

For Assistance, please call (773) 473-7080 to speak with one of our experts.

For fast, easy ordering, go to www.freeman.com/store

SHOWCASES

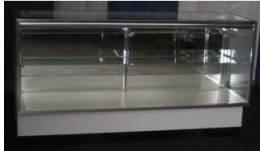

FULL VISION CASE



TOWER CASE

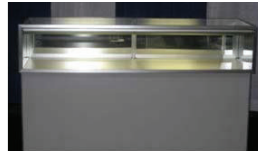

QUARTER VISION CASE



CORNER VISION CASE



WALLCASE



HALF VISION CASE

Qty	Part #	Description	Online Price	Discount Price	Standard Price	Total
FULL VISION CASE						
1-8" & 1-10" Glass Shelf with Adjustable Brackets						
26" High Front Glass Display Section						
Case is 20" Deep						
Available in 4', 5' and 6' lengths						
_____	101043	4'.....	\$870.15	\$957.15	\$1218.20	\$ _____
_____	101051	5'.....	\$870.15	\$957.15	\$1218.20	\$ _____
_____	101061	6'.....	\$870.15	\$957.15	\$1218.20	\$ _____

Qty	Part #	Description	Online Price	Discount Price	Standard Price	Total
QUARTER VISION CASE						
12" High Front Glass Display Section						
Case is 20" Deep						
Available in 4', 5' and 6' lengths						
_____	101044	4'.....	\$870.15	\$957.15	\$1218.20	\$ _____
_____	101052	5'.....	\$870.15	\$957.15	\$1218.20	\$ _____
_____	101062	6'.....	\$870.15	\$957.15	\$1218.20	\$ _____

HALF VISION CASE						
1-10" Glass Shelf with Adjustable Brackets						
18" High Front Glass Display Section						
Case is 20" Deep						
Available in 4', 5' and 6' lengths						
_____	101042	4'.....	\$870.15	\$957.15	\$1218.20	\$ _____
_____	101050	5'.....	\$870.15	\$957.15	\$1218.20	\$ _____
_____	101060	6'.....	\$870.15	\$957.15	\$1218.20	\$ _____

CORNER VISION CASE						
Includes Rear Access and Glass Shelves						
Case is 20" Deep						
Available in Full, Half, and Quarter Sizes						
*Cases on the sides in picture above are not included						
_____	101091	Full.....	\$1063.60	\$1169.95	\$1489.05	\$ _____
_____	101090	Half.....	\$1063.60	\$1169.95	\$1489.05	\$ _____
_____	101092	Quarter.....	\$1063.60	\$1169.95	\$1489.05	\$ _____

TOWER CASE						
Dimensions are 20"L x 20"D x 80"H						
3 Glass Shelves						
Lights						
Locks						
Available in 20 x 20 Square Only						
_____	1010200	20 x 20.....	\$1140.90	\$1255.00	\$1597.25	\$ _____

WALLCASE						
Dimensions are 48"L x 20"D x 72" H						
(4) 12" Glass Shelves						
Adjustable Brackets						
Lights						
Locks						
60" High Sliding Glass Doors						
Available in See-Thru (pictured above) and Solid						
_____	1010203	Solid.....	\$1102.15	\$1212.35	\$1543.00	\$ _____
_____	1010204	See-Thru.....	\$1102.15	\$1212.35	\$1543.00	\$ _____

- All showcases are 20"D x 38"H, have lights, locks, sliding mirror doors, gray exterior, and off-white interior aluminum frames.
- All keys must be left with the showcase or a charge of \$10.00 will be assessed.
- Electrical services are **NOT** included. Please order the electrical service from the electrical contractor.

TOTAL COST		
Sub-Total	+ Tax (9%)	= TOTAL

Take advantage of the Online price by ordering online at www.freeman.com/store

F R E E M A N

SHOWCASE PLACEMENT

The grid below may be printed to layout the placement of your showcase. Please complete as clearly as possible, indicating the following:

- Booth orientation.** Please provide surrounding aisle and/or booth numbers, particularly for island booths. Also, please try to orient your booth to the overall floor plan so that the diagram does not have to be rotated.

Show Name: _____ Dates: _____

Company Name: _____ Booth #: _____

Adjacent Aisle or Booth # _____

Adjacent Aisle or Booth # _____

Adjacent Aisle or Booth # _____

A measurement scale can be applied as necessary to reflect the size of your booth. (Minimum: 1 square = 1 foot)

SCALE: 1 SQUARE = _____ FOOT/FEET or _____ INCHES

FREEMAN

8201 West 47th St
 Mc Cook, IL 60525
 (773) 473-7080 Fax: (469) 621-5603
 FreemanChicagoES@freeman.com

**DISCOUNT PRICE
 DEADLINE DATE
 MARCH 12, 2020**

FREEMAN graphics

NAME OF SHOW: **NECANN - ILLINOIS CANNABIS CONVENTION / APRIL 3 - 4, 2020**

COMPANY NAME: _____ BOOTH #: _____ BOOTH SIZE: _____ X

CONTACT NAME: _____ PHONE #: _____

E-MAIL ADDRESS: _____

For Assistance, please call (773) 473-7080 to speak with one of our experts.

For fast, easy ordering, go to www.freeman.com/store

GRAPHICS

To order your graphics, complete this order form and attach your sign copy or electronic file.

Please see artwork guidelines for electronic files on page 2 of this form.

Note: All graphics are subject to a 100% Cancellation Charge.

DIGITAL GRAPHICS

Freeman has the capabilities to provide you with the finest digital graphic reproduction available. Capabilities include four-color, photo-quality, high-resolution digital printing virtually any size for banners, signage, exhibit graphics and more.

_____ L X _____ W = _____ sq.ft.

sq. ft. _____ \$ 25.20 per sq. ft. discount price
 x or = \$ _____
 \$ 37.80 per sq. ft. standard price

- Minimum order per graphic 9 sq. ft. (1296 sq. in.)
- Double sq. ft. for double-sided graphics
- Round sq. ft. to next whole increment
- File conversion, retouching, cloning or color correcting may incur additional labor charges. (See reverse side for graphic guidelines.)

LARGE DIGITAL GRAPHICS

Please call an Exhibitor Sales Specialist for price quotes on graphics over 80 sq. ft.

File Information:
 Electronic File Name _____

Application _____
 PMS Colors _____

Backing Material:

- | | |
|---|--|
| <input type="checkbox"/> Freeman Foam (Foamcore) | <input type="checkbox"/> Masonite |
| <input type="checkbox"/> Freeman PVC (PVC) | <input type="checkbox"/> Plexi |
| <input type="checkbox"/> Freeman HD Foam (Gatorfoam) | <input type="checkbox"/> Freeman Honeycomb (Eco-Board) |
| <input type="checkbox"/> Freeman Polyfoam (Ultra Board) | <input type="checkbox"/> Other |

The product offered has recycled content or has eco-friendly attributes and is 100% recyclable according to the manufacturer's specifications.

Vertical Horizontal Use Your Judgment For Sign Layout

Special Instructions

STANDARD SIZES

CHOOSE YOUR SIZE:

QTY.	Discount Price	Standard Price	TOTAL
7" x 11" @	46.55	69.85 =	_____
7" x 22" @	46.55	69.85 =	_____
7" x 44" @	65.50	98.25 =	_____
9" x 44" @	84.60	126.90 =	_____
11" x 14" @	46.55	69.85 =	_____
14" x 22" @	65.50	98.25 =	_____
14" x 44" @	130.85	196.30 =	_____
22" x 28" @	130.85	196.30 =	_____
28" x 44" @	108.30	162.45 =	_____
20" x 60" @	264.10	396.15 =	_____

(white only)

Note: File conversion, retouching, cloning or color may incur additional labor charges. (See reverse side for graphic guidelines.)

INDICATE YOUR SIGN COPY HERE:

* Please feel free to attach additional sign copy on separate page.

Vertical Horizontal Use Your Judgment For Sign Layout

Background Color: _____

Lettering Color: _____

TOTAL COST

Sub-Total	+	10.25 % Tax	=	Total Cost
-----------	---	-------------	---	------------

CUSTOMER GUIDELINES FOR SUBMITTING GRAPHICS ARTWORK

Our goal is to provide you with the best possible quality graphics for your event or exhibit. You can help us in that effort by providing digital art files using the following guidelines. If you are sending us completed, print-ready files, please pass the following information on to your graphics designer or art department. Artwork must be submitted in the proper resolution and/or file size to produce quality images. Please provide proper color matching information and proofs to ensure accurate color reproduction.

PLEASE PROVIDE THE FOLLOWING WHEN SUBMITTING ART

RASTER ART (photos, logos containing any continuous tone images):

- Art submitted at 1:1 (100%), resolution should be no less than 60 dpi (100 dpi preferred)
- Art submitted at 2:1 (50%), resolution should be no less than 120 dpi (200 dpi preferred)
- Art submitted at 4:1 (25%), resolution should be no less than 240 dpi (400 dpi preferred)

VECTOR ART:

- Logos should be vector and have outlined fonts (if provided as bitmap, please use high-res images)

FONTS and LINKS

- Supply all fonts used in your design (zip Mac fonts). If unsure how to collect fonts, convert them to outlines
- Supply all links used in your document. Use packaging feature if available. If unsure how to collect links, embed them in the file when saving.

COLOR

- If PMS color matching is required, please use original Pantone + Solid Coated swatches in your artwork. Modifying Pantone names will result in printing default color (CMYK)
- CMYK artwork will be produced "As Is". Our color output is balanced and vibrant.
- Convert RGB art to CMYK if possible.
- If you are sending Certified Color Proofs (Gracol, Swop, Fogra), please provide ICC file information used to print your samples. Best option would be to include ICC chart on your prints.

ARTWORK IN THE STRUCTURE

- Please note that any panels going in the metal frame will hide 1/4" of your art all the way around. If you have a continuous wall where individual panels are divided by metal, use 1.25" spacing in between each panel to account for gaps and the natural flow of the graphics.

ACCEPTABLE FILE SOFTWARE

We are capable of working with both PC and MAC based software, and can accept art created with the ADOBE Creative Suite - Illustrator, InDesign, and Photoshop

Always provide the following:

- Native files with fonts and links (zipped)
- High-res PDF-X/4 exports of the files

ACCEPTABLE FILE TYPES and SUPPORT FILES

NATIVE FILES:

- AI CLOUD (CC) file with Packaged supporting links and fonts. You may keep images linked but Packaging feature must be used.
- AI (CS6, CS5, CS4...) file with embedded links and outlined fonts
- EPS file with embedded links and outlined fonts
- INDD file with Packaged supporting links and fonts

PRINT FILES:

- High-res PDF-X/4 (preferred)
- AI with PDF content (choose this option when saving file)
- EPS files with embedded links and outlined fonts

RASTER OR BITMAP ART:

- Photoshop EPS (preferred, use 8-bit preview, Max, Quality JPG compression)
- PSD (make sure font layers are rasterized)
- TIFF, JPG (quality 8 and higher)

Mac users: Use Zip or Stuffit programs when submitting fonts other than OTF (Open Type Fonts)

WAYS TO SEND ARTWORK

• Files below 10 MB can be delivered via email. Larger files may be posted to Freeman's FTP site. You may get the password and other needed information from your Freeman service representative in order to post files. However, a hard copy proof and backup of the files on CD-Rom/DVD may be required to be sent via overnight delivery in addition to posting the electronic files. Please call (773) 473-7080 for assistance.

CHICAGO AREA UNION JURISDICTIONS

All exhibit and display work in the Chicago area must be done by union personnel.

There are six major unions that have jurisdiction over tradeshow. The following guidelines will help you in preparing your exhibit to conform to union jurisdiction and adherence to them can save you a substantial amount of money.

TEAMSTER UNION

Teamsters handle all freight inside the exhibit hall. They unload all trucks or vehicles, deliver the material to your booth and remove and reload material at the close of the show. The only exceptions to this are, machinery, which is handled by the Riggers and Machinery Movers Union, and small items which can be easily carried by one person, in one trip, without the aid of flat trucks, dollies, etc.

Exhibitor may carry in small packages including pop-up booths provided they can be hand-carried.

MACHINERY MOVERS & RIGGERS

(1) Riggers, as members of the union are usually referred to, handle all machines. This includes unloading machines from trucks, moving the materials to your booth and uncrating them if necessary. Riggers also remove skids and reskid machines and spot the machines in your booth.

(2) An exhibitor and exhibitor employees are permitted in a booth of any size to skid, position, and re-skid all exhibitor material, machinery and equipment.

(3) Consistent with safety and the skills and training necessary to perform the task, an exhibitor and exhibitor employees ("Exhibitor employee" means any person who has been employed by the exhibitor as a full-time employee for a minimum of 6 months before the show's opening date) are permitted in a booth of any size with the use of the exhibitor's ladders and hand tools to assemble and disassemble machinery or equipment.

(4) Please note: An exhibitor and exhibitor employees are prohibited at any time from using scooters, forklifts, pallet jacks, condors, scissor lifts, motorized dollies, or similar motorized or hydraulic equipment.

CARPENTERS UNION

Carpenters handle the erection and dismantling of display and exhibit booths. This includes all display work with the exception of machinery, signs or lighted headers, unless the sign or header is a permanently attached part of the display. Carpenters also recreate machines for outbound loading.

Exhibitors may set up and dismantle pop-up displays in booths of 10' x 10' or less. A pop-up display shall be defined as a display system of ten feet or less, that can be set up by one person in 1/2 hour or less, without the use of tools. Pop-up displays larger than 10 feet will require union labor.

CHICAGO AREA UNION JURISDICTIONS

DECORATORS UNION

Decorators handle installation of signs, drape background, table skirting, and other items of a decorative nature that must be done after a display background is erected, such as photos, and framed and unframed pictures.

Exhibitors may hang their own corporate logos, small pictures and graphics when such items are designed to be attached by pre-set velcro strips, permanently mounted hooks or snaps.

Exhibitors may set up and take down 10' x 10' displays ("pop-ups") if one person can accomplish the task in 1/2 hour or less without the use of tools.

Exhibitors may skirt table(s) provided they do it with their own custom fit skirts, without the use of staples, snaps or velcro.

Exhibitors may blow up balloons provided they are not used in the display.

ELECTRICAL UNION

Electricians handle all electrical work, which includes supplying power lines to your booth, connecting equipment to the proper outlets, and installing any signs or headers that are lighted, unless they are permanently attached to the exhibit backwall.

GENERAL PROVISIONS

In each case where these rules indicate that an "exhibitor may" do something, this is interpreted to mean a full-time employee of the exhibiting company (full time throughout the year. Verifiable documentation must be provided upon request).

Reasonable judgement must be used in determining when a task is so large or so time consuming as to require professional union labor.

WHAT YOU CAN DO WITHOUT UNIONS IN THE CHICAGO AREA

Contrary to popular belief, exhibitors are allowed to do a few jobs in the comfort and privacy of their own booth. Hopefully this guideline will help.

Exhibitors are allowed to unpack and repack their own product. This does not mean that because your product is a 10 ton assembly line, and is shipped in pieces, that you can assemble it; it means that if you are displaying some type of merchandise that comes in boxes, you can unpack and set out for display providing no tools are required to open boxes. Exhibitors are allowed to do the technical work on their machines, example: fine line balancing, programming, additional electrical work, in most cases, and cleaning of the machines.

EXHIBITOR AND OFFICIAL SERVICES CONTRACTOR INFORMATION

EXHIBITOR AND OFFICIAL SERVICES CONTRACTOR INFORMATION

Show Management has selected Freeman to be the Official Services Contractor for your upcoming show. As the Official Services Contractor, Freeman has the responsibility for material handling, electrical, all suspended rigging and booth cleaning services. We hope this document will assist you in planning for your upcoming event.

To help you understand the Official Services Contractor responsibilities, we ask that you read and observe the following to aid in a smooth and efficient move-in and move-out of the trade show.

Freeman requests that exhibitors do not tip its employees by giving money, merchandise or other special consideration for services rendered. Exhibitors should not give coffee breaks other than mid-morning and mid-afternoon when employees have a fifteen minute paid break. Any attempts to solicit a gratuity by an employee for any service should be reported immediately to a supervisor of Freeman. Freeman employees are paid an excellent wage and tipping is not an accepted company policy.

Freeman craftsmen at all levels are instructed to refrain from expressing any disputes or directly challenging the practices of any exhibitor. All questions arising with regard to the jurisdiction or practices must be directed to a FREEMAN management representative.

PER SHOW MANAGEMENT

<u>TASK</u>	<u>EXHIBITORS MAY</u>	<u>FREEMAN RESPONSIBILITIES</u>
Material Handling	<ul style="list-style-type: none"> • As an exhibitor you may “hand carry” material. Hand carry is defined as small items such as cartons and packages that an exhibitor is able to carry. • The assistance of any motorized device or pallet jack is not permitted. • When exhibitors choose to “hand carry” they may not access designated material handling areas. • Must use specified exhibitor hand carry areas or main entrance of the facility. • In all other circumstances items should be considered material handling. <p>In no circumstance is any exhibitor authorized to use Freeman material handling equipment for any purpose.</p>	<ul style="list-style-type: none"> • Freeman has been contracted to be the exclusive provider for material handling contract services as ordered by the exhibitor. • Freeman has the responsibility to manage all freight docks and to schedule all vehicles into and out of all designated material handling areas for the show. This will assure the smooth, orderly and efficient move in and move out of the tradeshow. • Freeman has the sole responsibility for loading and unloading all trucks, trailers, common and contract carriers at its facilities or designated material handling areas. • Freeman is not responsible for any material it does not handle. • For the convenience of all exhibitors on the show, forms for material handling services are included in this service manual and are available on Freeman’s website at www.freeman.com.
Electrical	<p>The following work may be performed by the exhibitor’s full-time company employees with positive identification such as a medical card or payroll stub but may not be performed by your Exhibitor Appointed Contractor (EAC).</p> <ul style="list-style-type: none"> • Plug in equipment into any 20A/120VAC receptacle. • May hang up to four small clip-on lights per booth. • May connect modems, printers, computers and keyboards, test and tune their own equipment, and run their own communications cable between machines in the same booth above the booth carpet. • Mounting of exhibitor owned monitors (to include plasma screens, LCD & CRT) and the installation of hanging brackets. 	<ul style="list-style-type: none"> • All electrical distribution. • All under-carpet electrical distribution. • Any additional electrical requirement needs or changes to preorders. • Distribution and connection of all power in excess of 20A/120V. • Distribution and connection of all 208V and 480V power. • Distribution of all electrical equipment necessary to provide electrical service. • Installation of all rental AV equipment.
Non-Electrical Ground Supported Signs	<ul style="list-style-type: none"> • Install and dismantle a non-electric sign attached to a booth by the exhibitor’s full-time employee or approved EAC. 	<ul style="list-style-type: none"> • Assembly and disassembly of hanging signs. • Hanging of non-electrical signs and decorative materials from the ceiling. • Installing chain hoist and attaching signs (over 200 lbs).

EXHIBITOR AND OFFICIAL SERVICES CONTRACTOR INFORMATION *(continued)*

TASK	EXHIBITORS MAY	FREEMAN RESPONSIBILITIES
Rigging / Electrical Hanging Signs and Truss	<ul style="list-style-type: none"> • Exhibitors <u>MAY NOT</u> install or assemble electrical hanging signs and truss. 	<ul style="list-style-type: none"> • Assembly and disassembly of electrical hanging signs, including rotating and header signs. • Lighting without dimmers. • Programmable theatrical lighting, production, related rigging and audio-visual. • Suspended trusses with or without legs that contain dimmable or programmable lighting, studio or motion picture lighting, sound system projectors and/or video wall. • Hoist ground-supported stand-alone truss whose sole purpose is overhead distribution of electrical. • Suspended truss with motorized hoist and non-dimmable and non-programmable lights. • Installing chain hoist. • Special effects equipment. • Laser lighting. • Video monitors and plasma screens including units fed by a live camera or are part of a multi-screen coordinated image.
Ground Supported Truss and Lighting	<ul style="list-style-type: none"> • Ground-supported truss that is considered to be "booth structure" or mixed-use truss may be assembled by you, your full-time employee or by an approved EAC. • Truss which is not assembled by Freeman is subject to all electrical rules and jurisdictions in regard to any electrical work in the truss. 	<ul style="list-style-type: none"> • Installation and dismantle of self-climbing and/or mechanized truss systems. • Installation and dismantle of any programmable dimmable lighting fixtures that are attached to any ground-supported truss. • Meeting room ground supported truss for the purpose of audio, visual, theatrical lighting.
Booth Cleaning and Porter Service	<ul style="list-style-type: none"> • Clean and wipe down products and display merchandise and other parts of the exhibit. • Exhibitor Appointed Contractors (EAC's) are not permitted to vacuum or utilize floor cleaning equipment on the show floor. 	<ul style="list-style-type: none"> • All booth vacuuming and porter service.
Booth Installation and Dismantle	<ul style="list-style-type: none"> • As an Exhibitor you may choose to utilize your own personnel to set up and dismantle your exhibit. • If full-time company personnel are utilized to set an exhibit, they should carry positive company identification, such as a medical identification card or payroll stub. • You may hire Freeman to act as your Exhibitor Appointed Contractor (EAC) to perform this work. • You may hire an Exhibitor Appointed Contractor (EAC) to perform this work. • All EAC's must have the appropriate credentials submitted to Show Management and the facility. 	<ul style="list-style-type: none"> • When it comes to installation and dismantling of exhibits, no one does it better than Freeman. With more than 75 years of experience, our group of specialists are ready to assist you with all of your exhibit requests from beginning to end. Whether you choose to supervise or you need the assistance of a full-time Freeman employee, we can meet all your needs, from shipping and storage to emergency on-site repairs to basic installation and dismantling to support service coordination including electrical, furnishings and more. Freeman has the resources and the capabilities to help you have the most successful show experience possible. • To secure Freeman labor, please utilize the labor forms enclosed. Skilled Freeman Labor is available to act as your EAC.
Cameras, Audio and Video Systems	<ul style="list-style-type: none"> • Install and operate their own manufactured or product systems when less than 20 amps or not suspended from the ceiling. • Plug in small sound devices. • Install exhibitor's own manufactured cameras by exhibitor's full time employees. • Exhibitors may elect to staff certain positions: <ul style="list-style-type: none"> • Technical Director • Lighting Designer • Video Engineer or Audio Engineer • Slow Motion Machine Operator • Advance Projectionist • Audio Board Operator • Video Board Operator • Live Camera Operator • Lighting Board Operator • Please contact Freeman with any questions. 	<p>Freeman will be responsible for the following staffing when an integrated system draws more than 20 amps or is suspended from the ceiling:</p> <ul style="list-style-type: none"> • Crane Operator • Audio Technician • TV Sound Boom Operator • Character Generator • Advanced Audio Visual Technician • Tape Operator • Audio Visual Technician • Video Wall Technician • Video Utility Person • Assistant TV Audio Tech • Projectionist • High Rigger • Ground Rigger • Lighting Tech

Please return form to:

NECANN
11 TONER BLVD, SUITE 5 - #331
NORTH ATTLEBORO, MA 02760
Attn: KRIS HULTGREN
Phone: 207-400-4446
Email: kris@necann.com

DEADLINE DATE

MARCH 5, 2020

NAME OF SHOW: **NECANN - ILLINOIS CANNABIS CONVENTION / APRIL 3 - 4, 2020**

EXHIBITING COMPANY NAME: _____ BOOTH #: _____

PRINT NAME: _____ BOOTH SIZE: _____ X _____

SIGNATURE: _____ DATE: _____

If your company plans to use a firm which is not the official service contractor as designated by Show Management, please complete this form and mail to the address listed above.

Company Name: _____ Booth No.: _____

Contact at Show: _____

Exhibitor Appointed Contractor: _____

Address of Contractor: _____

Type of Service to be Performed: _____

*Inform your **Exhibitor Appointed Contractor** that they **MUST** send a copy of their General Liability Insurance Certificate no later than **30 days** prior to the first day of exhibitor move-in or they will not be permitted to service your exhibit.*

It is the responsibility of the exhibitor to see that each representative of an Exhibitor Appointed Contractor abides by the official rules and regulations of this event.

This form must be received 30 DAYS PRIOR TO THE FIRST DAY OF EXHIBITOR MOVE-IN.

NOTIFICATION OF INTENT TO USE eac

F R E E M A N

8201 West 47th Street
 McCook, Illinois 60525
 (773) 473-7080 • Fax (469) 621-5603
 Email: FreemanChicagoES@freeman.com

**DISCOUNT PRICE
 DEADLINE DATE
 MARCH 12, 2020**

NAME OF SHOW: **NECANN - ILLINOIS CANNABIS CONVENTION / APRIL 3 - 4, 2020**

COMPANY NAME _____ BOOTH #: _____

CONTACT NAME: _____ PHONE #: _____

E-MAIL ADDRESS _____

For Assistance, please call 773-473-7080 to speak with one of our experts.

For fast, easy ordering go to www.freeman.com/store

CARPENTER LABOR (One Hour Minimum per Worker)

Description	Advance Price Per Hour	Standard Price Per Hour
Straight Time - 8:00 a.m. to 4:30 p.m. Monday through Friday	\$ 181.25	\$ 253.75
Overtime - 4:30 p.m. to 8:30 p.m. Monday through Friday; 6:00 a.m. - 6:30 p.m. Saturday	\$ 272.00	\$ 381.00
If a Display Laborer has not worked eight (8) straight time hours on that day between 8:00 a.m. and 4:30 p.m., Monday through Friday (Holidays excluded), Double Time rates will apply for that day during the hours of 6:30 p.m. to 8:30 p.m., Monday through Friday.		
Double Time - 8:30 PM - 8:00 AM Monday through Friday (unless noted above); Before 6:00 a.m. and after 6:30 p.m. Saturday; ALL DAY Sunday and Holidays.	\$ 362.50	\$ 507.50

NOTE: On the break of a show occurring on Monday through Friday, work performed from: 4:30 P.M. to 8:30 P.M. shall be charged in Straight Time; from 8:30 P.M. to Midnight shall be charged at Overtime (time and a half).

- Show Site prices will apply to all labor orders placed at show site.
- Price is per person/per hour
- Start time guaranteed only when labor is requested for the start of the working day (8:00 a.m.), unless the official set up time begins later in the day.
- One hour minimum per man--labor thereafter is charged in half (1/2) hour increments.
- Supervisor must check in at Service Desk to pick up laborers. Upon completion of work, supervisor must return to Service Desk to release laborers.
- Labor must be cancelled in writing, 24 hours in advance to avoid a one (1) hour cancellation fee per worker.
- When scheduling dismantle labor, be sure to allow sufficient time for empty containers to be returned to your booth.
- Freeman supervising jobs will be completed at our discretion prior to show opening and before the hall must be cleared.

Please include setup plan/photo, special instructions and inbound shipping information with this order.

INSTALLATION LABOR

SUPERVISION BY FREEMAN I & D Please complete the information on the reverse side

- Exhibits are set up prior to exhibitor's arrival under the direction of Freeman I & D Supervisors.
- The charge for this service is **30%** of the total installation labor bill, with a minimum of **\$45.00**.

Emergency Contact: _____ Phone Number: _____

SUPERVISION BY EXHIBITOR PERSONNEL

Supervisor will be: _____ Phone Number: _____

Date	Time	No. of People	Approx. Hours	Total Hours	Hourly Rate	Total Estimated Cost
_____	_____	_____	x _____	= _____	@ \$ _____	= \$ _____
_____	_____	_____	x _____	= _____	@ \$ _____	= \$ _____
Freeman Supervision (30%/\$45.00)						= \$ _____
Total Installation						= \$ _____

DISMANTLE LABOR

SUPERVISION BY FREEMAN I & D Please complete the information on the reverse side

- Freeman is not responsible for product or literature that is not properly packed and labeled by exhibitor.
- The charge for this service is **30%** of the total dismantle labor bill, with a minimum of **\$45.00**.

Emergency Contact: _____ Phone Number: _____

SUPERVISION BY EXHIBITOR PERSONNEL

Supervisor will be: _____ Phone Number: _____

Date	Time	No. of People	Approx. Hours	Total Hours	Hourly Rate	Total Estimated Cost
_____	_____	_____	x _____	= _____	@ \$ _____	= \$ _____
_____	_____	_____	x _____	= _____	@ \$ _____	= \$ _____
Freeman Supervision (30%/\$45.00)						= \$ _____
Total Dismantle						= \$ _____

FREEMAN carpenter installation & dismantle labor

F R E E M A N

FREEMAN carpenter installation & dismantle labor

NAME OF SHOW: **NECANN - ILLINOIS CANNABIS CONVENTION / APRIL 3 - 4, 2020**

COMPANY NAME: _____ BOOTH #: _____ BOOTH SIZE: **X**

CONTACT NAME: _____ PHONE #: _____

EMAIL ADDRESS: _____

FREEMAN SUPERVISED LABOR

IN ORDER TO BETTER SERVE YOU--PLEASE COMPLETE THE FOLLOWING INFORMATION IF YOUR DISPLAY IS TO BE SET-UP AND/OR DISMANTLED BY FREEMAN AND YOU WILL NOT BE PRESENT TO SUPERVISE THE INSTALLATION AND/OR DISMANTLE.

INBOUND SHIPPING INFORMATION AND SET-UP INFORMATION:

Freight will be shipped to: Warehouse _____ Show Site _____ Date _____

Total No. of: Crates _____ Cartons _____ Fiber Cases _____

Other (Specify) _____

Setup Plan/Photo: Attached _____ To Be Sent With Exhibit _____ In Crate No. _____

Carpet: With Exhibit _____ Rented From Freeman _____ Color _____ Size _____

Electrical Placement: Drawing Attached _____ Drawing With Exhibit _____ Electrical Under Carpet _____

Comments: _____

Graphics: With Exhibit _____ Shipped Separately _____

Comments: _____

Special Tools/Hardware Required: _____

OUTBOUND SHIPPING INFORMATION:

Ship To: _____

METHOD OF SHIPMENT

- FREEMAN EXHIBIT TRANSPORTATION**
 - Common Carrier
 - Air Freight Next Day 2nd Day Deferred
- OTHER CARRIER: (Please indicate the carrier's name)**
 - Other Common Carrier: _____
 - Other Air Freight: _____
 - Van Line: _____

FREIGHT CHARGES

Prepaid Collect

Bill To: _____

In the event your selected carrier fails to show on final move-out day, please select on of the following options:

- Reroute via Freeman's choice
- Delivery back to warehouse at Exhibitor's Expense.

PLEASE NOTE: Freeman will not be responsible for product or literature that is not properly packed and labeled by exhibitor personnel.

F R E E M A N

8201 West 47th Street
 McCook, Illinois 60525
 (773) 473-7080 • Fax (469) 621-5603
 Email: FreemanChicagoES@freeman.com

DISCOUNT PRICE
DEADLINE DATE
MARCH 12, 2020

NAME OF SHOW: NECANN - ILLINOIS CANNABIS CONVENTION / APRIL 3 - 4, 2020

COMPANY NAME _____ BOOTH #: _____

CONTACT NAME: _____ PHONE #: _____

E-MAIL ADDRESS _____

For Assistance, please call 773-473-7080 to speak with one of our experts.

For fast, easy ordering go to www.freeman.com/store

DECORATOR LABOR (One Hour Minimum per Worker)

Description	Advance Price Per Hour	Standard Price Per Hour
Straight Time - 8:00 A.M. to 4:30 P.M. Monday through Friday	\$ 181.25	\$ 253.75
Overtime - 4:30 P.M. to 8:30 P.M. Monday through Friday and 8:00 A.M. to 4:30 P.M. Saturday	\$ 272.00	\$ 381.00
Double Time - 8:30 PM - 8:00 AM Monday through Friday, 4:30 P.M. - 12:00 Midnight Saturday, ALL DAY Sunday and Holidays.....	\$ 362.50	\$ 507.50

NOTE: On the break of a show occurring on Monday through Friday, work performed from: 4:30 P.M. to 8:30 P.M. shall be charged in Straight Time; from 8:30 P.M. to Midnight shall be charged at Overtime (time and a half).

Show Site prices will apply to all labor orders placed at show site.

- Price is per person/per hour
 - Start time guaranteed only when labor is requested for the start of the working day (8:00 a.m.), unless the official set up time begins later in the day.
 - One hour minimum per man--labor thereafter is charged in half (1/2) hour increments.
 - Supervisor must check in at Service Desk to pick up laborers. Upon completion of work, supervisor must return to Service Desk to release laborers.
 - Labor must be cancelled in writing, 24 hours in advance to avoid a one (1) hour cancellation fee per worker.
 - When scheduling dismantle labor, be sure to allow sufficient time for empty containers to be returned to your booth.
 - Freeman supervising jobs will be completed at our discretion prior to show opening and before the hall must be cleared.
- Please include setup plan/photo, special instructions and inbound shipping information with this order.

INSTALLATION LABOR

SUPERVISION BY FREEMAN I & D Please complete the information on the reverse side

- Exhibits are set up prior to exhibitor's arrival under the direction of Freeman I & D Supervisors.
- The charge for this service is **30%** of the total installation labor bill, with a minimum of **\$45.00**.

Emergency Contact: _____ Phone Number: _____

SUPERVISION BY EXHIBITOR PERSONNEL

Supervisor will be: _____ Phone Number: _____

Date	Time	No. of People	Approx. Hours	Total Hours	Hourly Rate	Total Estimated Cost
_____	_____	_____	x _____	= _____	@ \$ _____	= \$ _____
_____	_____	_____	x _____	= _____	@ \$ _____	= \$ _____

REMINDER: Display Labor does not include the installation of any Electrical Materials or Equipment. (See Electrical Labor Order Form)

Freeman Supervision (30%/\$45.00) = \$ _____
 Total Installation = \$ _____

DISMANTLE LABOR

SUPERVISION BY FREEMAN I & D Please complete the information on the reverse side

- Freeman is not responsible for product or literature that is not properly packed and labeled by exhibitor.
- The charge for this service is **30%** of the total dismantle labor bill, with a minimum of **\$45.00**.

Emergency Contact: _____ Phone Number: _____

SUPERVISION BY EXHIBITOR PERSONNEL

Supervisor will be: _____ Phone Number: _____

Date	Time	No. of People	Approx. Hours	Total Hours	Hourly Rate	Total Estimated Cost
_____	_____	_____	x _____	= _____	@ \$ _____	= \$ _____
_____	_____	_____	x _____	= _____	@ \$ _____	= \$ _____

Freeman Supervision (30%/\$45.00) = \$ _____
 Total Dismantle = \$ _____

FREEMAN decorator installation & dismantle labor

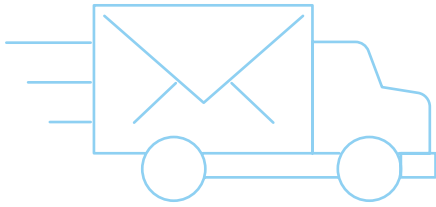

TRANSPORTATION SERVICE, FULLY LOADED.

Our convenient, affordable package puts productivity in overdrive.

Turn to Freeman for one-stop transportation services. Our all-inclusive round trip standard ground shipping and material handling package means transporting materials to any exhibit location has never been easier or more affordable. Plus, Freeman works directly with you and show site decision makers to streamline the process, so it's faster than ever to get on the road to success.

The Freeman Exhibit Transportation promise:

- ▮ ALL-INCLUSIVE PRICING WITH NO ADDITIONAL FEES FOR PICKUPS AND DELIVERIES, INCLUDING WEEKEND AND NIGHT SERVICE
- ▮ PICK-UP AND TRANSPORTATION FROM POINT OF ORIGIN TO YOUR CHOICE OF EITHER ADVANCE WAREHOUSE OR SHOW SITE
- ▮ ON-SITE TRANSPORTATION EXPERTS ARE AVAILABLE BEFORE, DURING AND AFTER THE SHOW
- ▮ RELIABLE CUSTOMER SERVICE SEVEN DAYS A WEEK, OFFERING COMPLETE SHIPMENT VISIBILITY AND EXPERT SUPERVISION
- ▮ PRE-PRINTED SHIPPING LABELS AND OUTBOUND PAPERWORK

Benefits:

- ▮ TURNKEY PRICING ENSURES PRECISE BUDGETING
- ▮ NO ADDITIONAL HANDLING, PICK-UP OR DELIVERY FEES
- ▮ NO ADDITIONAL FUEL SURCHARGES OR OVERTIME SURCHARGES
- ▮ NO CARRIER WAITING TIME FEES
- ▮ EXPERIENCED ON-SITE TRANSPORTATION REPS FROM MOVE-IN THROUGH MOVE-OUT
- ▮ LTL (LESS THAN TRUCK LOAD) SHIPPING

*Services apply to destinations anywhere in the Continental U.S.



To take advantage, call **1-800-995-3579** or email **exhibit.transportation@freeman.com** for a quote.

FREEMAN

(800) 995-3579 Toll Free US & Canada
(817) 607-5183 Local & International

COMPLETE THIS FORM ONLY IF YOU ARE
SHIPPING YOUR EXHIBIT MATERIALS BY
FREEMAN EXHIBIT TRANSPORTATION

FREEMAN exhibit transportation

NAME OF SHOW: **NECANN - ILLINOIS CANNABIS CONVENTION / APRIL 3 - 4, 2020**

COMPANY NAME: _____ BOOTH #: _____ BOOTH SIZE: _____ X

CONTACT NAME : _____ PHONE #: _____

E-MAIL ADDRESS : _____

For Assistance, please call applicable number listed above to speak with one of our experts.

For fast, easy ordering, go to www.freeman.com/store

EXHIBIT TRANSPORTATION

TIPS FOR EASY ORDERING

- Credit card information must be on file prior to pick up, as charges will be included on your show services invoice.
- International Exhibitors remember - Shipments originating from countries other than the US must be cleared through customs. Please call for additional information:
(800) 995-3579 Toll Free US & Canada
(817) 607-5183 Local & International

COMPLETE THE FOLLOWING ITEMS ON THIS FORM:

PICK UP INFORMATION

Requested Pick Up Date: _____

SHIPPER NAME _____

SHIPPER ADDRESS _____

(City) _____ (State) _____ (Zip Code) _____

DESTINATION

- I will be shipping to the **WAREHOUSE**

FREEMAN / Exhibiting Company Name / Booth #

NECANN - ILLINOIS CANNABIS CONVENTION

C/O: FREEMAN
2500 WEST 35TH ST
CHICAGO, IL 60632

MUST BE DELIVERED BY MARCH 26, 2020

- I will be shipping to **SHOW SITE**

FREEMAN / Exhibiting Company Name / Booth #

NECANN - ILLINOIS CANNABIS CONVENTION

C/O: FREEMAN
HILTON CHICAGO
725 SOUTH WABASH
CHICAGO, IL 606052116

CANNOT BE DELIVERED BEFORE APRIL 02, 2020

TYPE OF SERVICE

- Next Day Air: Delivery next business day by 5:00 PM
 Second Day Air: Delivery second business day by 5:00 PM
 3-5 Day Service: Delivery within 3 - 5 business days
 Declared Value \$ _____

Air Transportation charges are billed by Dimensional or Actual Weight, whichever is greater.

- Standard Ground: Dependent on distance
 Expedited Ground: Tailored to specific requirements
 Specialized: Pad wrapped, uncrated, truck load

SHIPPING INFORMATION

Items to be shipped

Number of Pieces	Est. Weight
____ Crates (wooden)	_____
____ Cartons (cardboard)	_____
____ Cases/Trunks (fiber) (color _____)	_____
____ Skids/Pallets	_____
____ Carpet (color _____)	_____
____ Other (_____)	_____
____ Total	_____

Size of largest piece: (H) _____ (W) _____ (L) _____

NOTE: Shipments will be weighed and measured prior to delivery.

OUTBOUND SHIPPING

- I would like to schedule outbound Freeman Exhibit Transportation. Please provide me with a Material Handling Agreement at show site for my shipping instructions and signature. So we may print your Outbound Material Handling Agreement and labels, please complete the following information **if different from pick up address:**

Ship to address:

Number of Labels : _____

FAX THIS COMPLETED FORM VIA:

E-mail:

exhibit.transportation@freeman.com

or

Fax: (469) 621-5810

**A TRANSPORTATION SPECIALIST
WILL CALL YOU TO CONFIRM
RECEIPT OF SHIPMENT REQUEST
AND FINALIZE DETAILS.**

SHOW # _____ (500503)

F R E E M A N

R U S H

DO NOT DELAY

F R E E M A N

R U S H

DO NOT DELAY

RECEIVING DATE BEGINS: MARCH 05, 2020

RECEIVING DATE BEGINS: MARCH 05, 2020

DEADLINE DATE IS: MARCH 26, 2020

DEADLINE DATE IS: MARCH 26, 2020

TO: _____
EXHIBITOR NAME

TO: _____
EXHIBITOR NAME

C/O: FREEMAN
2500 WEST 35TH ST

CHICAGO, IL 60632

C/O: FREEMAN
2500 WEST 35TH ST

CHICAGO, IL 60632

WAREHOUSE

WAREHOUSE

EVENT: _____
NECANN - ILLINOIS CANNABIS CONVENTION

EVENT: _____
NECANN - ILLINOIS CANNABIS CONVENTION

BOOTH NO: _____ **NO.** _____ **OF** _____ **PCS**

BOOTH NO: _____ **NO.** _____ **OF** _____ **PCS**

THE ABOVE LABELS ARE PROVIDED FOR YOUR CONVENIENCE.
PLACE ONE ON EACH PIECE SHIPPED TO ENSURE PROPER DELIVERY.
IF MORE LABELS ARE NEEDED, COPIES ARE ACCEPTABLE.

F R E E M A N

F R E E M A N

R U S H

R U S H

DO NOT DELAY

DO NOT DELAY

CANNOT DELIVER BEFORE APRIL 02, 2020

CANNOT DELIVER BEFORE APRIL 02, 2020

TO: _____
EXHIBITOR NAME

TO: _____
EXHIBITOR NAME

C/O: FREEMAN
HILTON CHICAGO
725 SOUTH WABASH

CHICAGO, IL 606052116

C/O: FREEMAN
HILTON CHICAGO
725 SOUTH WABASH

CHICAGO, IL 606052116

SHOW SITE

SHOW SITE

EVENT: **NECANN - ILLINOIS CANNABIS**
 CONVENTION

EVENT: **NECANN - ILLINOIS CANNABIS**
 CONVENTION

BOOTH NO: _____ NO. _____ OF _____ PCS

BOOTH NO: _____ NO. _____ OF _____ PCS

THE ABOVE LABELS ARE PROVIDED FOR YOUR CONVENIENCE.
PLACE ONE ON EACH PIECE SHIPPED TO ENSURE PROPER DELIVERY.
IF MORE LABELS ARE NEEDED, COPIES ARE ACCEPTABLE.

WHAT ARE FREIGHT SERVICES?

As the official service contractor, Freeman is the exclusive provider of freight services. Material handling includes unloading your exhibit material, storing up to 30 days in advance at the warehouse address, delivering to the booth, the handling of empty containers to and from storage, and removing of material from the booth for reloading onto outbound carriers. It should not be confused with the cost to transport your exhibit material to and from the convention or event. You have two options for shipping your advance freight — either to the warehouse or directly to show site.

HOW DO I SHIP TO THE WAREHOUSE?

- We will accept freight beginning 30 days prior to show move-in.
- To check on your freight arrival, call Exhibitor Services at the location listed on the Quick Facts.
- To ensure timely arrival of your materials at show site, freight should arrive by the deadline date listed on the Quick Facts. Your freight will still be received after the deadline date, but additional charges will be incurred.
- The warehouse will receive shipments Monday through Friday, except holidays. Refer to the Quick Facts for warehouse hours. No appointment is necessary.
- The warehouse will accept crates, cartons, skids, trunks/cases and carpets/pads. Loose or pad-wrapped material must be sent directly to show site.
- All shipments must have a bill of lading or delivery slip indicating the number of pieces, type of merchandise and weight.
- Shipments received without receipts or freight bills, such as Federal Express and UPS, will be delivered to the booth without guarantee of piece count or condition.
- Certified weight tickets must accompany all shipments.
- Warehouse freight will be delivered to the booth prior to exhibitor set up.

HOW DO I SHIP TO SHOW SITE?

- Freight will be accepted only during exhibitor move-in. Please refer to the Quick Facts for the specific exhibitor move-in dates and times.
- All shipments must have a bill of lading or delivery slip indicating the number of pieces, type of merchandise and weight.
- Shipments received without receipts or freight bills, such as Federal Express and UPS, will be delivered to the booth without guarantee of piece count or condition.
- Certified weight tickets must accompany all shipments.

WHAT ABOUT PREPAID OR COLLECT SHIPPING CHARGES?

- Collect shipments will be returned to the delivery carrier.
- To ensure that your freight does not arrive collect, mark your bill of lading “prepaid.”
- “Prepaid” designates that the transportation charges will be paid by the exhibitor or a third party.

HOW SHOULD I LABEL MY FREIGHT?

- The label should contain the exhibiting company name, the booth number and the name of the event.
- The specific shipping address for either the warehouse or show site is located on the Quick Facts.

HOW DO I ESTIMATE MY MATERIAL HANDLING CHARGES?

- Charges will be based on the weight of your shipment. Each shipment received is billed individually and is subject to the applicable show weight minimum. The shipment weight will be rounded to the next 100 pounds. Each 100 pounds is considered one “cwt.” (one hundred weight). All shipments are subject to reweigh.
- On the Material Handling Order Form, select whether the freight will arrive at the warehouse or be sent directly to show site.
- Next, select the rate for the freight category that best describes your shipment. There are four categories of freight:

Crated: material that is skidded or is in any type of shipping container that can be unloaded at the dock with no additional handling required.

Special Handling: material delivered by the carrier in such a manner that it requires additional handling, such as ground unloading, stacked and constricted space unloading, designated piece unloading, loads mixed with pad-wrapped material, loads failing to maintain shipping integrity, and shipments that require additional time, equipment or labor to unload. Federal Express and UPS are included in this category due to their delivery procedures.

Uncrated: material that is shipped loose or pad-wrapped, and/or unskidded machinery without proper lifting points.

Carpet and/or Pad Only: shipments that consist of loose carpet and/or padding only require additional labor and equipment to unload.

- All inbound and outbound shipments are subject to overtime charges if the shipments are received, loaded or unloaded during the overtime hours specified on the Material Handling Order Form. This includes both warehouse and show site shipments.
- Add any late delivery or off-target charges listed on the Material Handling Order Form if the freight will be received after the deadlines listed on the Quick Facts.
- The above services, whether used completely or in part, are offered as a package and the charges will be based on the total inbound weight of the shipment.

WHAT HAPPENS TO MY EMPTY CONTAINERS DURING THE SHOW?

- Pick up “Empty Labels” at the Freeman Service Center. Once the container is completely empty, place a label on each container individually. Labeled empty containers will be picked up periodically and stored in non-accessible storage during the event.
- At the close of the show, the empty containers will be returned to the booth in random order. Depending on the size of the show, this process may take several hours.

HOW DO I PROTECT MY MATERIALS AFTER THEY ARE DELIVERED TO THE SHOW OR BEFORE THEY ARE PICKED UP AFTER THE SHOW?

- Consistent with trade show industry practices, there may be a lapse of time between the delivery of your shipment(s) to your booth and your arrival. The same is true for the outbound phase of the show — the time between your departure and the actual pick-up of your materials. During these times, your materials will be left unattended. We recommend that you arrange for a representative to stay with your materials or that you hire security services to safeguard your materials.

HOW DO I SHIP MY MATERIALS AFTER THE CLOSE OF THE SHOW?

- Each shipment must have a completed Material Handling Agreement in order to ship materials from the show. All pieces must be labeled individually.
- To save time, complete and submit the Outbound Shipping Form in advance, or you may contact the Freeman Service Center at show site for your shipping documents.
- Once we receive your outbound shipping information we will create your Material Handling Agreement and shipping labels. If the shipping information is provided in advance, the Material Handling Agreement will be delivered to your booth with your invoice. Otherwise the Material Handling Agreement and labels will be available for pick up at the Freeman Service Center.

- After materials are packed, labeled, and ready to be shipped, the completed Material Handling Agreement must be turned in at the Freeman Service Center.
- Call your designated carrier with pick-up information. Please refer to the Quick Facts for specific dates, times and address for pick up. In the event your selected carrier fails to show by the final move-out day, your shipment will either be rerouted on Freeman’s carrier choice or delivered back to the warehouse at the exhibitor’s expense.
- For your convenience, approved show carriers will be on site to book outbound transportation if you have not made arrangements in advance.

WHERE DO I GET A FORKLIFT?

- Forklift orders to install or dismantle your booth after materials are delivered may be ordered in advance or at show site. We recommend that you order in advance to avoid additional charges at show site. Refer to the Rigging Order Form for available equipment.
- Advance and show site orders for equipment and labor will be dispatched once a company representative signs the labor order at the Freeman Service Center.
- Start time is guaranteed only when equipment is requested for the start of the working day.

DO I NEED INSURANCE?

- Be sure your materials are insured from the time they leave your firm until they are returned after the show. It is suggested that exhibitors arrange all-risk coverage. This can be done by riders to your existing policies.
- All materials handled by Freeman are subject to the Terms and Conditions, which can be found in the exhibit service manual or online at www.freeman.com.

OTHER AVAILABLE FREIGHT SERVICES

(may not be available in all locations)

- Cranes
- Accessible storage at show site
- Exhibit transportation services (see enclosed brochure)
- Security storage at show site
- Short-term and long-term warehouse storage
- Local pick-up and delivery
- Priority empty return

F R E E M A N

8201 West 47th Street
 McCook, Illinois 60525
 (773) 473-7080 • Fax (469) 621-5603
 Email: FreemanChicagoES@freeman.com

NAME OF SHOW: NECANN - ILLINOIS CANNABIS CONVENTION / APRIL 3 - 4, 2020

COMPANY NAME _____ BOOTH #: _____

CONTACT NAME: _____ PHONE #: _____

E-MAIL ADDRESS _____

For Assistance, please call 773-473-7080 to speak with one of our experts.

Let Freeman OnLine® estimate your material handling charges for you. Log on to www.freeman.com/store, select your show and click on "Estimate My Material Handling Costs". From Freeman OnLine® you can print extra shipping labels, get tips on how to package your freight and much more.

MATERIAL HANDLING SERVICES

- Crated:** Material that is skidded or is in any type of shipping container that can be unloaded at the dock with no additional handling required.
- Special Handling:** Material delivered by a carrier in such a manner that it requires additional handling, such as ground unloading, stacked or constricted space unloading, designated piece unloading, shipment integrity, alternate delivery location, loads mixed with pad wrapped material, no documentation and shipments that require additional time, equipment or labor to unload. **Federal Express, UPS, & DHL** are included in this category due to their delivery procedures.
 (See definitions on back)
- Uncrated:** Material that is shipped loose or pad-wrapped, and/or unskidded machinery without proper lifting points.
- Carpet and/or Pad Only:** Shipments that consist of loose carpet and/or padding only require additional labor and equipment to unload.
- Straight Time -** 8:00 A.M. to 4:30 P.M. Monday through Friday
- Overtime -** 4:30 P.M. to 8:00 A.M. Monday through Friday; ALL DAY Saturday
- Double Time-** ALL DAY Sunday and Holidays
 (Overtime/Double Time will be applied to all freight received at the warehouse and/or show site that must be moved into or out of booth during above listed times.)

Description	Price per CWT	200 lbs. Minimum
-------------	---------------	------------------

RATE CLASSIFICATIONS:

Warehouse Shipment (200 lb. minimum)- Includes Outbound Overtime Charges.

Crated or Skidded Shipment	\$ 222.75	\$ 445.50
Special Handling Shipment	\$ 289.75	\$ 579.50
Carpet and/or Pad Only Shipment	\$ 334.25	\$ 668.50

Showsite Shipment (200 lb. minimum)- Includes Outbound Overtime Charges.

Crated or Skidded Shipment	\$ 231.00	\$ 462.00
Special Handling Shipment	\$ 300.50	\$ 601.00
Uncrated or Pad Wrapped Shipment	\$ 346.75	\$ 693.50
Carpet and/or Pad Only Shipment	\$ 346.75	\$ 693.50

Small Package - Maximum weight is 30 lbs. per shipment* \$ 45.00

* A small package shipment is a shipment totaling any number of pieces with a combined weight not to exceed 30 lbs. that is received on the same day, from the same shipper and delivered by the same carrier.

ADDITIONAL SURCHARGES:

Shipment Delivered after Deadline Date (in addition to above rates)

Warehouse Shipment after MARCH 26, 2020	\$ 44.25	\$ 88.50
Showsite Shipment after APRIL 2, 2020	\$ 46.25	\$ 92.50

Overtime Charge - Inbound/Outbound Monday-Friday & Saturday (in addition to above rates)

Crated or Skidded Shipment	\$ 46.25	\$ 92.50
Special Handling Shipment	\$ 60.25	\$ 120.50
Uncrated or Pad Wrapped Shipment	\$ 69.50	\$ 139.00
Carpet and/or Pad Only Shipment	\$ 69.50	\$ 139.00

Double Time Charge - Inbound/Outbound Sunday, & Holidays (in addition to above rates)

Crated or Skidded Shipment	\$ 92.50	\$ 185.00
Special Handling Shipment	\$ 120.25	\$ 240.50
Uncrated or Pad Wrapped Shipment	\$ 138.75	\$ 277.50
Carpet and/or Pad Only Shipment	\$ 138.75	\$ 277.50

Description	Weight	CWT	Price per CWT	Estimated Total Cost
	÷ 100 =			
Surcharges	÷ 100 =			
			Sub-Total	
			TOTAL	

FREEMAN material handling

SPECIAL HANDLING DEFINITIONS

For frequently asked questions and material handling estimator tools, go to www.freeman.com/store

Special handling applies to shipments that are loaded by cubic space and/or packed in such a manner as to require additional labor/handling, such as ground unloading, constricted space unloading, designated piece unloading, carpet/pad only shipments or stacked shipments. Also included are shipment integrity, alternate delivery locations, mixed shipments and shipments without individual bills of lading. Shipments loaded in this manner require additional time, labor, or equipment to unload, sort, and deliver.

What is Ground Loading/Unloading?

Vehicles that are not dock height, preventing the use of loading docks, such as U-Hauls, flat bed trailers, double drop trailers, company vehicles with trailers that are not at dock level, etc.

What is Constricted Space Loading/Unloading?

Trailer loaded "high and tight" shipments that are not easily accessible. Freight is loaded to full capacity of trailer--top to bottom, side to side. One example of this is freight that is loaded down one side of a trailer that must be by-passed to reach target freight.

What is Designated Piece Loading/Unloading?

Drivers that require the loading crew to bring multiple pieces of the freight to the rear of the trailer to select the next piece, having to remove freight from the trailer then reload to fit or the trailer must be loaded in a sequence to ensure all items fit.

What are Stacked Shipments?

Shipments loaded in such a manner requiring multiple items to be removed to ground level for delivery to booth. Stacked or "cubed out" shipments, loose items place on top of crates and/or pallets constitute special handling.

What is Shipment Integrity?

Shipment integrity involves shipments on a carrier that are intermingled, or delivered in such a manner that additional labor is needed to sort through and separate the various shipments on a truck for delivery to our customers.

What is Alternate Delivery Location?

Alternate Delivery Location refers to shipments that are delivered by a carrier that requires us to deliver some shipments to different levels in the same building or to other buildings in the same facility.

What are Mixed Shipments?

Mixed shipments are defined as shipments of mixed crated and uncrated goods, where the percentage of uncrated is minimal and does not warrant the full uncrated rate for the shipment, but does require special handling. Freeman defines special handling for mixed loads as having less than 50% of the volume as uncrated.

What does it mean if I have "No Documentation"?

Shipments arrive from a small package carrier (including, among others, Federal Express, UPS, & DHL) without an individual Bill of Lading, requiring additional time, labor, and equipment to process.

What is the difference between Crated and Uncrated Shipments?

Crated shipments are those that are packed in any type of shipping container that can be unloaded at the dock with no additional handling required. Such containers include crates, fiber cases, cartons, and properly packed skids. An uncrated shipment is material that is shipped loose or pad wrapped, and/or unskidded without proper lifting points.

What about carpet only shipments?

Shipments that consist of loose carpet and/or padding only require additional labor and equipment to unload.

F R E E M A N

8201 West 47th Street
 McCook, Illinois 60525
 (773) 473-7080 • Fax (469) 621-5603
 Email: FreemanChicagoES@freeman.com

**DISCOUNT PRICE
 DEADLINE DATE
 MARCH 12, 2020**

NAME OF SHOW: NECANN - ILLINOIS CANNABIS CONVENTION / APRIL 3 - 4, 2020

COMPANY NAME _____ BOOTH #: _____

CONTACT NAME: _____ PHONE #: _____

E-MAIL ADDRESS _____

For Assistance, please call 773-473-7080 to speak with one of our experts.

For fast, easy ordering go to www.freeman.com/store

RIGGING EQUIPMENT AND LABOR

STRAIGHT TIME HOURS

8:00 a.m. to 4:30 p.m., Monday through Friday

Day the Show Closes - 4:30 p.m. to 8:30 p.m., Monday through Friday

***Flexible Start Times** - 10:00 a.m. to 6:30 p.m. and 12:30 p.m. to 8:30 p.m. Monday through Friday

- Must be ordered 24 hours in advance
- Four (4) hour minimum charge
- Rigger availability not guaranteed
- After 4:30 p.m. the prorated share of stewards costs may be an additional charge
- Six (6) hour minimum applies after four (4) hours

OVERTIME HOURS

Monday through Friday

4:30 p.m. to 6:30 p.m.

***Flexible Start Times**

6:30 p.m. to 8:30 p.m. with 10:00 a.m. start

8:30 p.m. to 10:30 p.m. with 12:30 p.m. start

Day the Show Closes - 8:30 p.m. to 12:30 a.m.

Saturday - All Day

DOUBLE TIME HOURS

Monday through Friday

After 6:30 p.m.

***Flexible Start Times**

After 8:30 p.m. with 10:00 a.m. start

After 10:30 p.m. with 12:30 p.m. start

Day the Show Closes - 12:30 a.m. to 8:00 a.m.

Sunday and Holidays - All Day

This form is a Machinery/Forklift/Rigging order form to uncrate, unskid, spot and place equipment. This form will not be accepted for your Hanging Sign/Condor needs.

Part #	Description	Advance Price per Hour	Standard
Forklift Labor and Equipment (Half hour minimum)			
3040520	5M Forklift / 2 Man Crew - ST	\$ 530.00	\$ 742.50
3040521	5M Forklift / 2 Man Crew - OT	\$ 718.00	\$1005.50
3040522	5M Forklift / 2 Man Crew - DT	\$ 905.50	\$1268.00
Two Man Rigging Crew (Half hour minimum)			
3020500	Rigging Crew - ST (Equipment not included).....	\$ 375.50	\$ 526.00
3020501	Rigging Crew - OT (Equipment not included)	\$ 563.50	\$ 789.00
3020502	Rigging Crew - DT (Equipment not included).....	\$ 751.00	\$1051.50
Two man crew is required with all equipment below (Half hour minimum per forklift)			
304015	Lg.Forklift (up to 15,000 lbs - Crew not included)	\$ 203.50	\$ 285.00
30404	4-Stage Forklift (14' or higher - Crew not included)	\$	Quoted on Request
3090600	Man Cage for Forklift.....	\$ 92.00	\$ 128.80
3090700	Boom for Forklift.....	\$122.25	\$ 171.15

PLEASE NOTE: There may be situations due to safety concerns or unusual circumstances where the contractor, at their discretion, may need to modify crew size.

**Please complete and return Page 2 with your
 Method of Payment Form**

FREEMAN forklift / rigging labor

F R E E M A N

8201 West 47th Street
 McCook, Illinois 60525
 (773) 473-7080 • Fax (469) 621-5603
 Email: FreemanChicagoES@freeman.com

**DISCOUNT PRICE
 DEADLINE DATE
 MARCH 12, 2020**

FREEMAN forklift / rigging labor

NAME OF SHOW: **NECANN - ILLINOIS CANNABIS CONVENTION / APRIL 3 - 4, 2020**
 COMPANY NAME _____ BOOTH #: _____
 CONTACT NAME: _____ PHONE #: _____
 E-MAIL ADDRESS _____

For Assistance, please call 773-473-7080 to speak with one of our experts.

For fast, easy ordering go to www.freeman.com/store

RIGGING EQUIPMENT AND LABOR

Please complete the forms below and return with your completed Method of Payment Form.

INSTALLATION

Part #	Description	Date	Start Time	# of Equip/ Person	Approx Hrs per Person	Total Hours	Hourly Rate	Estimated Total Cost
Describe work to be done: _____							Sub-Total	
_____							Tax	N/A
							Total	

DISMANTLE

Part #	Description	Date	Start Time	# of Equip/ Person	Approx Hrs per Person	Total Hours	Hourly Rate	Estimated Total Cost
Describe work to be done: _____							Sub-Total	
_____							Tax	N/A
							Total	

DIRECTIONS TO HILTON CHICAGO

CAR TRAFFIC

From O'Hare Airport:

Follow signson Kennedy Expressway (90/94) east to Chicago. Exit east at Congress Parkway. Turn right (south) at either Wabash Avenue or Michigan Avenue to Balbo Drive.

From Midway Airport:

Take Cicero Avenue to the Stevenson Expressway (55) heading east. Follow sign to Lake Shore Drive (north). Turn left (west) at Balbo Drive. Continue to Michigan Avenue or Wabash Avenue.

From the West:

Go east on the Eisenhower Expressway (290) which becomes Congress Parkway. Turn right (south) at either Wabash Avenue or Michigan Avenue to Balbo Drive.

From the South:

Go north on Lake Shore Drive to Balbo Drive. Turn left (west) and continue to either Michigan Avenue or Wabash Avenue.

From the North:

Take the Kennedy Expressway east to Chicago Loop and exit east at Congress Parkway. Turn right (south) at either Wabash Avenue or Michigan Avenue to Balbo Drive.

OR

Go south on Lake Shore Drive to Balbo Drive. Turn right (west) and continue to either Michigan Avenue or Wabash Avenue.

TRUCK TRAFFIC

From the West:

Go east on the Eisenhower Expressway (290). Exit 90/94 South. Continue to Roosevelt Road. Turn left (east) and continue to Wabash Avenue. Turn left (north) to Hilton Chicago.

From the South or North:

Use 90/94, exit Roosevelt Road. Turn left (east) and continue until Wabash Avenue. Turn left (north) to Hilton Chicago.

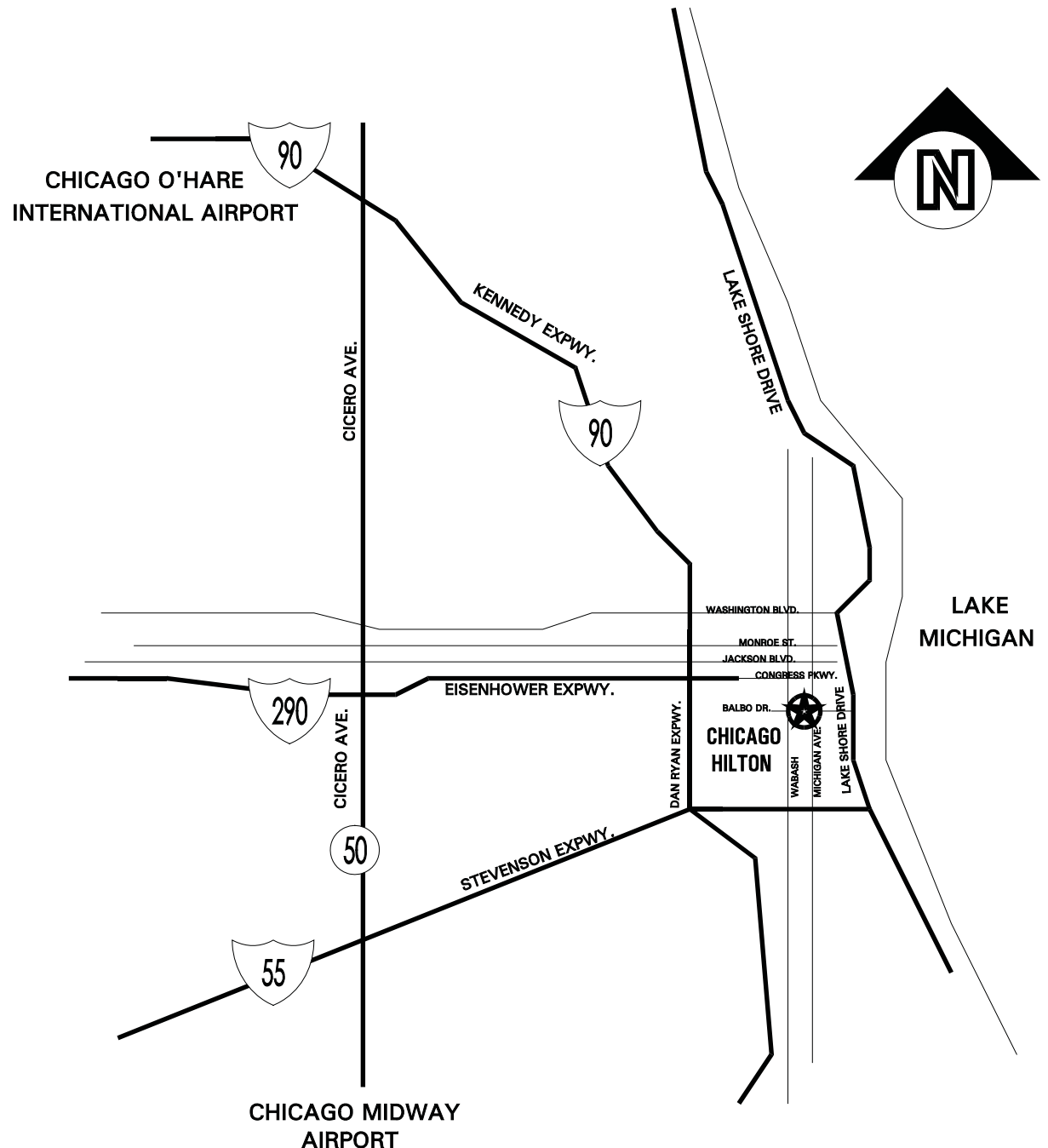

FREEMAN

8201 West 47th St
Mc Cook, IL 60525
(773) 473-7080 Fax: (469) 621-5603
FreemanChicagoES@freeman.com

NAME OF SHOW: **NECANN - ILLINOIS CANNABIS CONVENTION / APRIL 3 - 4, 2020**

COMPANY NAME: _____ BOOTH #: _____ BOOTH SIZE: _____ X

CONTACT NAME : _____ PHONE #: _____

E-MAIL ADDRESS : _____

For Assistance, please call (773) 473-7080 to speak with one of our experts.

For fast, easy ordering, go to www.freeman.com/store

EVERY OUTBOUND SHIPMENT WILL REQUIRE A MATERIAL HANDLING AGREEMENT AND SHIPPING LABELS. WE WOULD BE HAPPY TO PREPARE THESE FOR YOU AND DELIVER THEM TO YOUR BOOTH PRIOR TO SHOW CLOSE. TO TAKE ADVANTAGE OF THIS SERVICE, PLEASE COMPLETE AND RETURN THIS FORM TO THE FREEMAN SERVICE CENTER.

SHIPPING INFORMATION

SHIP TO: COMPANY NAME: _____

DELIVERY ADDRESS: _____

CITY: _____ STATE/ PROVINCE: _____ ZIP/ POSTAL CODE: _____

PHONE#: _____ ATTN: _____

SPECIAL INSTRUCTIONS: _____

BILL TO: Same as Ship to:

COMPANY NAME: _____

DELIVERY ADDRESS: _____

CITY: _____ STATE/ PROVINCE: _____ ZIP/ POSTAL CODE: _____

METHOD OF SHIPMENT

Select a Carrier:

- Freeman Exhibit Transportation Other Carrier

No need to schedule your outbound shipment.
Charges will appear on your Freeman invoice.

Carrier Name: _____
Carrier Phone: _____

Freeman will make arrangements for all Freeman Exhibit Transportation shipments.
Arrangements for pick-up by other carriers is the responsibility of the exhibitor.

Select a Level of Service:

- 1 Day: Delivery next business day Standard Ground
 2 Day: Delivery by 5:00 PM second business day Specialized: Pad wrapped, uncrated, or truckload
 Deferred: Delivery within 3-5 business days

Select Shipment Options (if applicable)

- Have loading dock Lift gate required
 Inside delivery Air ride required
 Pad wrap required Residential
 Do not stack

Select Desired Number of Labels: _____

Once your shipment is packed and ready to be picked up from your booth, please return completed the Material Handling Agreement to the Freeman Service Center. Shipments without a Material Handling Agreement turned in will be returned to our warehouse at exhibitor's expense.



ATTENTION EXHIBITORS:

When working with a general contractor it is recommended that all exhibitor freight and anything in relation to your individual booth be routed through them. The Hilton Chicago's in house Parcel Center, FedEx is physically unable to store large amounts of packages. All packages sent to and accepted by the FedEx Parcel Center will be charged the standard receiving fees.

It is the responsibility of all exhibitors to send their materials to the General Contractor in the following manner.

COMPANY NAME: _____

SHOW NAME: _____

BOOTH NUMBER(S): _____

c/o FREEMAN
2500 West 35th Street
Chicago, Illinois 60632

All materials shipped directly to the Hilton Chicago c/o Freeman before the date indicated on your show site labels will be accepted by the Hotel Parcel Center, FedEx handling fees will be billed by FedEx and will need to be paid before they release your packages.

WE APPRECIATE YOUR COOPERATION.

F R E E M A N



WELCOME TO THE HILTON CHICAGO & TOWERS

*In compliance with the directives of the Chicago Fire Prevention Bureau, we ask that **ALL EXHIBITORS** read and strictly adhere to the following:*

Please be aware that equipment, products, material, or containers of ANY KIND MAY NOT, under any circumstances be stored under any tables, behind any drape, or behind any booth displays. You may keep one day's supply of your product or materials on display in the open area of your booth space.

Any items stored behind a booth display or drape will be subject to removal and will be placed in an off-site storage facility. These items will be returned at the close of show.

"Empty" labels are provided for your convenience and are available at the Freeman Service Desk. Please affix these to your empty containers and place them in the aisle for pick-up. They will be returned to your booth at the break of show.

If any booth is found not to be in compliance, the Fire Marshal reserves the right to close down that booth. Those exhibitors not in compliance are responsible for any services rendered.

THANK YOU FOR YOUR COOPERATION.

Hilton Chicago Management

F R E E M A N
IS PROUD TO SERVE AS THE RECOMMENDED CONTRACTOR



GENERAL FIRE SAFETY POLICIES & PROCEDURES

STATEMENT OF PURPOSE:

General fire safety policies and procedures have been established to ensure the Hilton Chicago, its guests, clients, personnel and related service industries are working in a safe environment, and in compliance with City of Chicago statutes governing fire prevention. These policies and procedures should serve as a guideline for all concerned and will be enforced by Hilton Chicago Management. Any requests for variations or exceptions should be directed to the Exhibit Hall Department of the Hilton Chicago, and must be approved in writing by hotel management.

1. All material, including scenery, drapes, signs, etc., used in construction of an exhibit booth **MUST** be flame retardant. Polyurethane foam must pass the "standard flame test". Only fire retardant cardboard and paper may be used. Affix certificate of flame proofing to the booth.
2. No storage of any kind is allowed behind the back drapes, behind booth displays, or under tables. A maximum of one-day's supply of materials may be placed in an OPEN AREA of your booth space.
3. No hazardous demonstrations, such as welding, cooking with natural gas, heater demonstrations, etc. will be permitted without the written approval of the Chicago Fire Prevention Bureau. A copy of all paperwork regarding the request and the approval of the procedure from the Fire Department should be forwarded to the Hotel's Exhibit Hall Manager.
4. Use of hazardous materials is **NOT** permitted at any time during an exhibit show. Hazardous materials include: open flames, hot coals, propane, gasoline, kerosene, radioactive material, oxygen, etc.
5. Vehicles or apparatus with fuel tanks for display **MUST** have a locking fuel cap and the fuel cap **MUST** be sealed using heavy tape and contain no more than 1/8 tank of fuel. Battery cable **MUST** be disconnected prior to vehicle entering the building.
6. Exhibits with enclosed ceilings **ARE NOT PERMITTED**. All exhibits **MUST** be **NO HIGHER THAN 10 FEET TALL**. All exhibits should remain 18" below the sprinkler system. Helium balloons are **NOT** permitted.
7. Floor plans of all exhibit booths exceeding 200 square feet must be submitted to Exhibit Hall Manager no less than 30 days before show opening.
8. All fire hose cabinets, pull stations, and emergency exits must be visible and accessible at all times.
9. All main and cross aisles, corridors, stairways, and other exit areas must maintain the required minimum width of 8 feet. No protrusions into the aisles are permitted.
10. Smoking is **NOT PERMITTED** during set-up or tear-down of shows, and is restricted to authorized areas at any other time.
11. Cut trees, branches and shrubs are prohibited in the hotel. Live plants must be maintained in their natural state.
12. Report emergencies immediately by dialing 55 on any house phone.

ALL QUESTIONS AND CLARIFICATIONS SHOULD BE DIRECTED TO:

HILTON CHICAGO
EXHIBIT HALL MANAGER
720 S. Michigan Avenue
Chicago, IL 60605
Phone: (312) 663-6535
Fax: (312) 431-6904



720 South Michigan Avenue, Chicago, Illinois 60605 Telephone 312/922-4400 Fax 312/922-5240
Reservations 1-800-HILTONS

Proud Recipients of the Awards of Excellence, the Pinnacle Award, the M&D Award and the Inner Circle Award

Chicago Fire Department Regulations

In order to minimize the risk of fire and to keep exhibit halls in Chicago as safe as possible, the Chicago Fire Department has established the following regulations:

The Municipal Code states that **nothing** (for example: fiber cases, cartons, boxes, personal items, giveaways, etc.) may be stored behind or between exhibits booths, behind draperies or under tables. All materials that are needed for repacking purposes must be removed from the exhibit area.

You may keep a one-day supply of literature or products at your booth. Accessible storage is available for additional promotion items or giveaways. Please see the General Service Contractor at the service desk for assistance.

The Chicago Fire Department strictly enforces these regulations.

F R E E M A N

8201 West 47th Street
McCook, IL 60525
(773) 473-7080 • Fax (469) 621-5603
Email: FreemanChicagoES@freeman.com

**DISCOUNT PRICE
DEADLINE DATE
MARCH 12, 2020**

**INCLUDE THE FREEMAN METHOD OF
PAYMENT FORM WITH YOUR ORDER**

FREEMAN electrical & plumbing

NAME OF SHOW: **NECANN - ILLINOIS CANNABIS CONVENTION / APRIL 3 - 4, 2020**

COMPANY NAME _____ BOOTH #: _____

CONTACT NAME: _____ PHONE #: _____

E-MAIL ADDRESS _____

For Assistance, please call 773-473-7080 to speak with one of our experts.

For fast, easy ordering go to www.freeman.com

Description	Qty.	Discount Price	Standard Price	Total
ELECTRICAL SERVICE				
BASIC POWER				
110/120 SINGLE PHASE				

1500 watt single outlet	_____	\$210.00	\$280.00	\$ _____
2000 watt single outlet	_____	\$250.00	\$290.00	\$ _____
Above 30 amps or 2000 watts			Quoted on Request	

HIGH POWER				
208 SINGLE PHASE				

15 amps single outlet	_____	\$450.00	\$550.00	\$ _____
20 amps single outlet	_____	\$500.00	\$600.00	\$ _____
30 amps single outlet	_____	\$600.00	\$700.00	\$ _____
Above 30 amps or 3000 watts			Quoted on Request	

208 THREE PHASE				
------------------------	--	--	--	--

15 amps single outlet	_____	\$500.00	\$600.00	\$ _____
20 amps single outlet	_____	\$650.00	\$700.00	\$ _____
30 amps single outlet	_____	\$1000.00	\$1200.00	\$ _____
Above 30 amps or 3000 watts			Quoted on Request	

ELECTRICAL LABOR				
-------------------------	--	--	--	--

One Half Hour Minimum charge for delivery & hook up of all A/V equipment (computers, monitors, on site order, etc.)

STRAIGHT TIME\$ 102.00
OVERTIME\$ 151.00
DOUBLETIME.....\$ 204.00

Description	Qty.	Discount Price	Standard Price	Total
ADDITIONAL EQUIPMENT				

Power Strip (Does not include electrical)	_____	\$35.00	\$40.00	\$ _____
10' extension cord	_____	\$15.00	\$20.00	\$ _____
Above 30 amps or 300 watts			Quoted on Request	

Outlets will be powered down overnight.

Outlets requiring 24-hour service or dedicated circuits will be at double the rates.

Please complete the grid on the next page to indicate location of electrical power or drains.

PLUMBING SERVICES

WATER, COMPRESSED AIR, WASTE LINES

- Available on special written request.** Price dependent upon location of booth. Please specify amount, size, and type of service desired, with detailed drawings of equipment connections. Estimated charges are subject to reasonable adjustment due to any increase in labor costs occurring before the date of the show.
- All equipment and material furnished on this order by the Chicago Hilton shall remain the property of the hotel.

• Check one:

_____ Steamfitter _____ PSI
_____ Plumber (for Compressed Air Line)

(80 PSI limit) <Written Request Enclosed>

TOTALS

ELECTRICAL SERVICES TOTAL

_____ + _____ = _____
Total Price Tax (9%) TOTAL

ELECTRICAL LABOR TOTAL

_____ x _____ = _____
No. of Workers Per Hour TOTAL

TOTAL COST

_____ + _____ = _____
SERVICES LABOR TOTAL

QUICK TIPS FOR EASY EXHIBITING

- If you have questions or need assistance in completing your order, please call the Exhibit Hall Dept. at the Hilton Chicago at 312/922-4400, Ext. 6535.
- Discount Pricing --Applies to all orders when accompanied with full payment and received prior to the discount deadline date.**
- To ensure order processing, full payment must accompany your order.**

F R E E M A N

ELECTRICAL SERVICES

The grid below may be printed to layout your electrical requirements for booths up to 40' x 40' or used to develop your own plan for larger exhibits. Please complete as clearly as possible, indicating the following:

- 1. Location of the main power drop.** (Power needs to be distributed from one location at which a panel or other piece of electrical equipment will be installed. It is recommended that this equipment be placed in a closet, under a table/desk or in another location that keeps it out of sight.) Please provide specific dimensions.
- 2. Location and load to all outlets.** Please provide specific dimensions and wattages/amperages. *Please do not simply place an X where your power is required.*
- 3. Booth orientation.** Please provide surrounding aisle and/or booth numbers, particularly for island booths. Also, please try to orient your booth to the overall floor plan so that the diagram does not have to be rotated.

Show Name: _____ Dates: _____

Company Name: _____ Booth #: _____

Adjacent Aisle or Booth # _____

A large grid for layout planning, consisting of 40 columns and 40 rows of squares. The grid is surrounded by labels: 'Adjacent Aisle or Booth #' at the top, bottom, left, and right. The grid is intended for drawing booth layouts and electrical requirements.

Adjacent Aisle or Booth # _____

A measurement scale can be applied as necessary to reflect the size of your booth. (Minimum: 1 square = 1 foot)

SCALE: 1 SQUARE = _____ FOOT/FEET or _____ INCHES

SKILLED PROFESSIONALS AND COST-CONSCIOUS CHARGES

To free you from unnecessary problems or delays at the show, we urge you to review this summary of electrical requirements applicable to all exhibitors (These requirements are based on the City of Chicago Electrical Code). In addition, if you are not familiar with basic safety standards for electrical wiring, an electrician should be consulted before shipment is made to the Hilton Chicago. If you need further information or clarification on any point, please write to the attention of the Hilton Chicago Exhibition Hall Manager.

BEFORE YOU SHIP, CHECK YOUR EQUIPMENT AGAINST THESE REQUIREMENTS

- All wiring and electrical equipment requires evidence of testing and approval by a nationally recognized testing laboratory.
- All electrical signs shall have permanent nameplate stating (1) size in feet and inches (2) weight and (3) maximum ampere load of the sign.
- All wiring that touches the floor must be "SO" cord, rated for extra hard usage.
- Wiring above floor level must be "SJ" cord, rated for hard usage.
- Zip cord is prohibited.
- Flexible cords must be 3-wire unless part of a specifically approved assembly.
- Motors of 3/4 HP and over must be equipped with a safety switch.
- Open clip sign sockets, latex or lamp cord wire in displays, duplex or triplex attachment plugs, are prohibited.

AT THE EXHIBITION

- Electrical fixtures that are part of your display must be installed during set-up and removed during pack-up by hotel electricians who are union members, whether an order has been placed or not. Charges will be made accordingly. All jobs are a minimum of one half hour time.
- General illumination of the area is provided.
- All outlets will be installed on the floor of the backwall of the standard booth. Connections from outlets to equipment shall be time and material.
- Any electrical connections to the building electrical systems, or extensions thereto, must be made by building electricians, not by the exhibitor.
- Extensions to the electrical system must be made by 3-wire flexible cord, type SO or equal, in lengths arranged so that there will be no more than one coil, 2 feet in diameter, of excess cord.
- Any cord run across a traffic lane must be encased in a substantial enclosure specifically approved for the purpose.
- No electrical equipment shall be attached to, or supported from, booth dividers.
- Permanently installed wiring on booths or displays must be encased in an approved metal raceway. Where flexibility is necessary, such as between booth sections or at connection points to the building system, type SO cord or equal, in lengths not to exceed 6 feet, with approved attachment plugs, may be used.
- Splices and terminations shall be made in an approved metal enclosure.
- All electrical material and equipment must use 3-wire cord and be grounded. Because of local and national ordinances, connections where wiring constitutes a fire hazard will not be allowed.

IMPORTANT NOTES

- All exhibits will be carefully inspected to determine if violations exist. If they do, qualified electricians are available to correct them. The work will be performed on a time and material basis. If the exhibitor does not wish to have the fault corrected, electrical services will not be connected.
- All material and equipment furnished by Hilton Chicago will remain the property of the Hilton Chicago.



STAND OUT ON THE EXHIBIT FLOOR

The Hilton Chicago chose PSAV as its official audiovisual provider because they trust us and know we'll provide you with the best experience possible. We'll collaborate with you as your partner to ensure you achieve your exhibition objectives and provide an unforgettable experience for your potential customers.

You Can Depend on Us

Our highly trained experienced professionals will be on the show floor throughout the event to provide technical assistance and to fulfill any last-minute requests using our diverse on-site inventory.

Cutting-Edge Technology

From 40" monitors to laptops to 1 Gb/s reliable internet access to mapping full-motion graphics on uneven surfaces and everything in between, PSAV offers the latest professional-grade technology.

Legendary Customer Service

What truly sets PSAV apart from the competition is our unparalleled customer service. We'll help you every step of the way to bring your vision to life.

ORDER EXHIBITOR SERVICES ▶

To access and print the order form visit
<http://venuepartners.psav.com/hiltonchicago>

Erika Janis

Sales Coordinator - PSAV®

Hilton Chicago

720 South Michigan Avenue, Chicago, IL 60605

■ **office:** 312.663.6524 ■ **email:** hiltonexhibits@psav.com



EXHIBITOR SERVICES FREQUENTLY ASKED QUESTIONS

Q What are the deadlines and/or cut-off dates?

A The deadline to complete and fax/email all forms will be 72 hours prior to the setup day of your show. All orders received after the 72-hour cut-off date will be considered on-site orders and will incur a 15% ADDITIONAL SERVICE CHARGE. EQUIPMENT WILL BE SUBJECT TO AVAILABILITY.

Q How will I know my order was received?

A Once your completed forms have been emailed to PSAV, a written confirmation should be received within 48 hours of receipt.

Q How do I submit payment?

A Contact PSAV at 312.663.6524 to provide your credit card information 72 HOURS BEFORE THE DAY OF THE SHOW TO ENSURE EQUIPMENT DELIVERY.

Q When will my credit card be charged?

A All credit cards will be charged for the entire amount of the order on the first day of the show.

Q How do I obtain a receipt?

A Receipts for completed orders will be issued once the credit card is charged on the day of the event.

Q If I have a question during the show, whom do I contact?

A PSAV will have on-site technicians available during the entirety of the show. If you are unable to locate a PSAV technician, please call our office at 312.663.6524.

ORDER EXHIBITOR SERVICES 

To access and print the order form visit
<http://venuepartners.psav.com/hiltonchicago>

Erika Janis
Sales Coordinator - PSAV®
[Hilton Chicago](#)
720 South Michigan Avenue, Chicago, IL 60605
■ office: 312.663.6524 ■ email: hiltonexhibits@psav.com

